

HYDRAULIC FILTRATION

INSTALLATION,
SERVICE AND
MAINTENANCE MANUAL

DEH

HAZARDOUS AREA
DIFFERENTIAL
CLOGGING
INDICATOR



EN

PASSION  PERFORM



PRODUCT OVERVIEW

DEH series of ATEX Hazardous Area Differential Clogging Indicator

Designed to thrive in hazardous work environments, the indicators provide critical early warnings for operators, alerting them that filter elements need to be cleaned or changed.

Suitable for a wide variety of applications from oil, sea and gas to industrial production plants, the indicators have been designed to prevent machinery failures, reduce unplanned downtime, and improve safety.

Features & Benefits

The DEH series features three different models each with a distinct connection type.

- Construction from AISI 316L Stainless steel
- 420 bar (6,091 PSI) maximum working pressure
- Approved for use in hazardous environments
- UK Ex, ATEX, IECEx, UL/CSA and EAC TR CU certifications
- Compact and reliable design
- Fully tested to one million cycles at maximum working pressure





PRODUCT OVERVIEW

Product Presentation

Filter elements are efficient only if their dirt holding capacity is fully exploited. This is achieved by using filter housings equipped with DEH Series ATEX Electrical Differential Indicators.

These devices switches when the filter elements become blocked which causes an increase in the pressure drop across the filter.

The indicator is set to alarm before the element becomes fully clogged. This indicator will reduce the frequency of replacing filter elements as well as maximising the performance of each filter.

- Constructed from AISI 316L stainless steel 420 bar (6,091 PSI)
- 420 bar (6,091 PSI) maximum working pressure
- Approved for use in hazardous environments
- UK Ex, ATEX, IECEx, UL/CSA and EAC TR CU certifications
- Temperature class T4 (135 °C) and T6 (85 °C)
- Protection grade IP 66/67/68 when used with suitable cable gland
- Indication range from 2 bar to 10 bar
- Suitable for use with all MP Filtri stainless steel pressure filters and cast iron pressure filters

Benefits

- Prevents machinery failures
- Cuts unplanned downtime
- Critical early warning system
- Saves time and costs
- Improves safety

Disclaimer

As part of our policy of continual improvement, MP Filtri reserves the right to alter the specification without prior notification.

Area of Application

Hazardous Area Electrical Differential Indicators can only be used in the appropriate zone classification.

Ex d indicators should only be used in zones 1 and 2 - zones in which potentially explosive atmospheres created by gases, vapours or mists are unlikely to occur in normal operation. In the event of an occurrence, the situation will persist for only a short period.

Ex ia indicators can be used in zones 0, 1 and 2. These are suitable in an area where explosive atmospheres are continually present. For more information please see section 6 - Certification.

The full range of applications the DEH series is designed for includes:

- Marine
- Mining
- Petrochemical
- Offshore oil and gas
- Saw mills
- Paper mills
- Car plants
- Industrial plants
- Storage silos
- Hazardous environments



TABLE OF CONTENTS

	Page
Product overview	1
Product Presentation	3
1 General warnings and information for the Operator	6
1.1 General safety warnings	6
1.2 Operator informations and Warnings	8
2 Warranty, Limitations and Disclaimers	10
3 Technical Specification	12
3.1 General Specification	12
3.2 Dimensions	14
3.3 Designation & Ordering code	14
3.4 Wiring Diagrams	15
3.5 Temperature Range	15
4 Product Installation and Maintenance Instructions	16
4.1 Correct Usage	16
4.2 Wiring Instructions	16
4.3 Suitable Operating Fluids	17
4.4 Commissioning	17
4.5 Electrical Connections	17
4.6 System Requirements Ex ia	18
5 Related Products	18
5.1 Spare Parts	18
6. Reference Certification	19
6.1 ATEX	19
6.2 IECEx	19
6.3 UL/CSA	20
6.4 EAC TR CU	20
6.5 Conditions of Safe Use of EX ia and EX d	20
6.6 Fatigue Declaration / Identification Statement	21
7 Servicing	22
7.1 General Information	22
7.2 Torque Values	22
7.3 Service Measures	22
7.4 Service Intervals	22
7.5 Seal Replacement	22
7.6 Removing the Electrical Differential Indicator	23
7.7 Installing the Electrical Differential Indicator	23

1 General warnings and information for the Operator

1.1 General Safety Warnings

Do not operate, maintain or carry out any procedure before reading this manual. Any individual operating the unit shall wear the following Personal Protective Equipment:

- Protective eyewear
- Safety shoes
- Gloves
- Overalls (or other suitable protective clothing)

Before carrying out any machine installation procedures and/or before use, one should scrupulously follow the instructions listed in this manual. Moreover, it is necessary to comply with the current regulations related to occupational accident prevention and safety in the workplace.

Notices aimed at the prevention of health hazards for personnel operating the machine are highlighted in this document with signs having the following meaning:

It relates to important information concerning the product, its use or part of this documentation to which special attention must be paid



NOTE

It means that failure to comply with the relevant safety regulations may result in mild injury or property damage



CAUTION

It means that failure to comply with the relevant safety regulations may result in death, serious injury or serious property damage.



DANGER

Failure to comply with the relevant safety regulations may result in death, serious injury or serious property damage.

GENERAL WARNINGS

To allow rapid identification of the employees who must read this manual, definitions have been used with the following meaning:

OPERATOR	This is any individual whose task is to use the machine for production purposes. The operator is aware of all the measures taken by the machine manufacturer in order to eliminate any source of injury risk in the workplace and takes into account the operational constraints.
PERSONNEL INVOLVED IN SLINGING AND HOISTING OPERATIONS	This is any individual whose task is to handle the machine or parts of it. Personnel involved in slinging and hoisting operations are aware of the issues regarding the safe transfer of machinery or parts of it and, therefore, uses appropriate lifting equipment, following the instructions provided by the product manufacturer.
MACHINE SETTER	This is any individual whose task is to set up the machine for its operation. The machine setter is aware of the measures taken to eliminate all sources of injury risks in the workplace and takes into account the operational constraints. The machine setter takes all the appropriate precautions in order to operate in utmost safety conditions.
MAINTENANCE TECHNICIAN	This is any individual whose task is to carry out maintenance activities on the machine. The maintenance technician is aware of the possible danger situations that may arise and takes the appropriate precautions in order to eliminate the risks of accidents in the workplace.
ELECTRICIAN	This is any individual whose task is to carry out maintenance activities on the electrical wiring of the machine. The electrician is aware of the possible danger situations that may arise and takes the appropriate precautions in order to eliminate the risks of accidents in the workplace.

1.2 Operator Information and Warnings

- This pressure unit must only be operated in conjunction with the appropriate machine or system.
- The pressure unit must only be used in strict accordance with the requirements of the operating instructions of the machine or system.
- This pressure unit must only be operated using hydraulic or lubricating fluid.



NOTE

- The user must, by appropriate action (e.g. venting), prevent the formation of air pockets.
- Repair, maintenance work, and commissioning must be carried out by trained personnel only. Personnel must ensure the pressure unit has cooled down before handling. Operating instructions for the machine or system must be strictly followed.
- Statutory accident prevention regulations, safety regulations and safety data sheets for fluids must be observed.
- When working on, or in the vicinity of, the hydraulic system, naked flames, spark generation and smoking are strictly forbidden.
- Hydraulic oils and water polluting fluids must not be allowed to enter the soil, watercourses or sewerage systems. Operators must ensure safe and environmentally-friendly disposal of hydraulic oils. The relevant regulations in the country concerned with regard to ground water pollution, used oil and waste must be followed.
- When work is carried out on the filter, operators must be prepared for the escape of hot oil. This can cause injury or scalding due to high pressure or high temperature.
- The Filter housing must be earthed when hydraulic hoses are used to connect the filter to the system.



CAUTION

- Before any work is carried out on the pressure unit, operators must ensure the pressure chamber concerned (filter housing) is depressurised.
- No alterations, such as welding, drilling, or opening by force, are to be carried out on the pressure unit.
- When using electrical clogging indicators, the electrical power supply to the system must be switched off before removing the clogging indicator connector.



DANGER

GENERAL WARNINGS

2 Warranty, Limitations and Disclaimers

MP Filtri warrants that the products that it manufactures and sells will be free from defects in material, workmanship & performance for a period of 12 months from the date of shipment.

Hardware/Firmware

Should the hardware prove defective during the warranty period, MP Filtri, at its discretion, will either repair the defective product or replace it with an equivalent product in exchange for the defective unit without charge for parts, labour, carriage and insurance.

Eligibility

This warranty extends to the original purchaser only or to the end-user client of a MP Filtri authorised affiliate.

How to obtain service?

To obtain service under the terms of this warranty, the customer is required to notify MP Filtri before the expiration of the warranty period and to return the item in accordance with MP Filtri product return policy. Any product returned for warranty repair must be accompanied by a full fault report specifying the symptoms and the conditions under which the fault occurs. Should MP Filtri incur additional cost as a result of a failure to complete the appropriate paperwork, an administrative charge may be levied.

Exclusions

This warranty shall not apply to any defect, failure or damage caused by improper use or improper or inadequate care. MP Filtri shall not be obligated to provide service under this warranty if:

- a) Damage has been caused by a failure to make a full and proper inspection of the product (as described by the documentation enclosed with the product at the time of shipment) on initial receipt of the product following shipment;
- b) Damage has been caused by the attempts of individuals, other than MP Filtri staff to repair or service the product;
- c) Damage has been caused by the improper use or a connection with incompatible equipment or product including software applications.

WARRANTY

Charges

Under cover of this warranty, MP Filtri will pay the carriage and insurance charges for the shipment of defective product back to site of manufacture and for its return to the client's original site of despatch except when:

a) MP Filtri product return policy has not been followed.

b) Product failure is caused by any of the exclusions described above, when the customer will be liable for the full cost of the repair (parts and labour) plus all carriage and insurance costs to and from MP Filtri premises.

c) The product is damaged in transit and a contributory cause is inadequate packaging. It is the customer's responsibility to ensure that the packaging used to return equipment to MP Filtri is the same, or has equivalent protective qualities, to that used to ship the product to the customer in the first instance. Any damage resulting from the use of inadequate packaging will nullify MP Filtri obligations under this warranty. Should the customer's product be damaged in transit following a repair at MP Filtri site, a full photographic record of the damage must be obtained (packaging and the product) to support any claim for recompense. Failure to present this evidence may limit MP Filtri obligations under this warranty.

THIS WARRANTY IS GIVEN BY MP FILTRI IN LIEU OF ANY OTHER WARRANTIES, EXPRESS OR IMPLIED, INCLUDING BUT NOT LIMITED TO ANY IMPLIED WARRANTY OF MERCHANTABILITY, NON INFRINGEMENT OR FITNESS FOR A PARTICULAR PURPOSE. MP FILTRI LTD SHALL NOT BE LIABLE FOR ANY SPECIAL, INDIRECT, INCIDENTAL OR CONSEQUENTIAL DAMAGES OR LOSSES (INCLUDING LOSS OF DATA), WE SPECIFICALLY DISCLAIM ANY AND ALL WARRANTIES TO CUSTOMERS OF THE CUSTOMER. THE CUSTOMER'S SOLE REMEDY FOR ANY BREACH OF WARRANTY IS THE REPAIR OR REPLACEMENT, AT MP FILTRI DISCRETION, OF THE FAILED PRODUCT.

MP Filtri maintains a policy of product improvement and reserves the right to modify the specifications without prior notice.

3. Technical Specification

3.1 General specification

Type of indicator	Electrical Switch
Weight	5 m cable (P01 model): 750 gr (approx) - 10m cable (P02 model): 1 kg M12 Short model: 270 gr (approx)
Seal material	Various
Pressure setting	2 bar - 10 bar (29 psi - 145 psi)

DEH 48 SERIES - 5 METER CABLE INDICATOR Ex ia IIC T4/T6 M20

PROPERTIES

Housing material	AISI 316L Stainless steel
Body shape	Cylindrical
Connection type	M20 x 1.5 - Three-core cable polyrad supplied with 5 or 10 metres
Temperature range	From -60 °C to +125 °C (from -76 to 257 °F) - UK Ex, ATEX, IECEx, UL/CSA, EAC TR CU
Contact type	SPCO/SPDT (Hermetically sealed - Volt-free contacts)
Contact material	Rhodium
Dimensions	114 x 28 mm
Ingress Protection	IP 66/67/68 according to EN 60529

ELECTRICAL RATINGS

Ui	30 Vdc
Li	250 mA
Pi	1.3 W

TECHNICAL SPECIFICATION

DEH 49 SERIES - 5 METER CABLE INDICATOR Ex d IIC T4/T6 1/2" NPT / UL Class I Div 1

PROPERTIES

Housing material	AISI 316L Stainless steel
Body shape	Cylindrical
Connection type	1/2" NPT - Four-core cable polyrad supplied with 5 or 10 metres
Temperature range	-60 °C to +120 °C (-76 to 248 °F) - UK Ex , ATEX, IECEx, TR CU -60 °C to +105 °C (-76 to 221 °F) - UL/CSA
Contact type	SPCO/SPDT (Hermetically sealed - Volt-free contacts)
Contact material	Rhodium
Dimensions	114 x 28 mm
Ingress Protection	IP 66/67/68 according to EN 6052

ELECTRICAL RATINGS

Supply Voltage	24 Vdc - 110 Vac
Maximum switching current	830 mA - 180 mA
Maximum voltage	150 Vac/dc
Power Watts	20 W

DEH 70 SERIES - M12 INDICATOR Ex ia IIC T6 RESIN SWITCH

PROPERTIES

Housing material	AISI 316L Stainless steel with internal engineered resin switch
Body shape	Cylindrical
Connection type	IEC 61076-2-101 D (M12) connector - plastic
Temperature range	-20 °C to +80 °C (-4 to 176 °F) - UK Ex, ATEX, IECEx, UL/CSA, EAC TR CU
Contact type	SPCO/SPDT (Hermetically sealed - volt free contacts)
Contact material	Rhodium
Dimensions	90 x 28mm
Ingress Protection	IP 66/67 according to EN 6052

ELECTRICAL RATINGS

Ui	30 Vdc
Li	250 mA
Pi	1.3 W

3.2 Dimensions

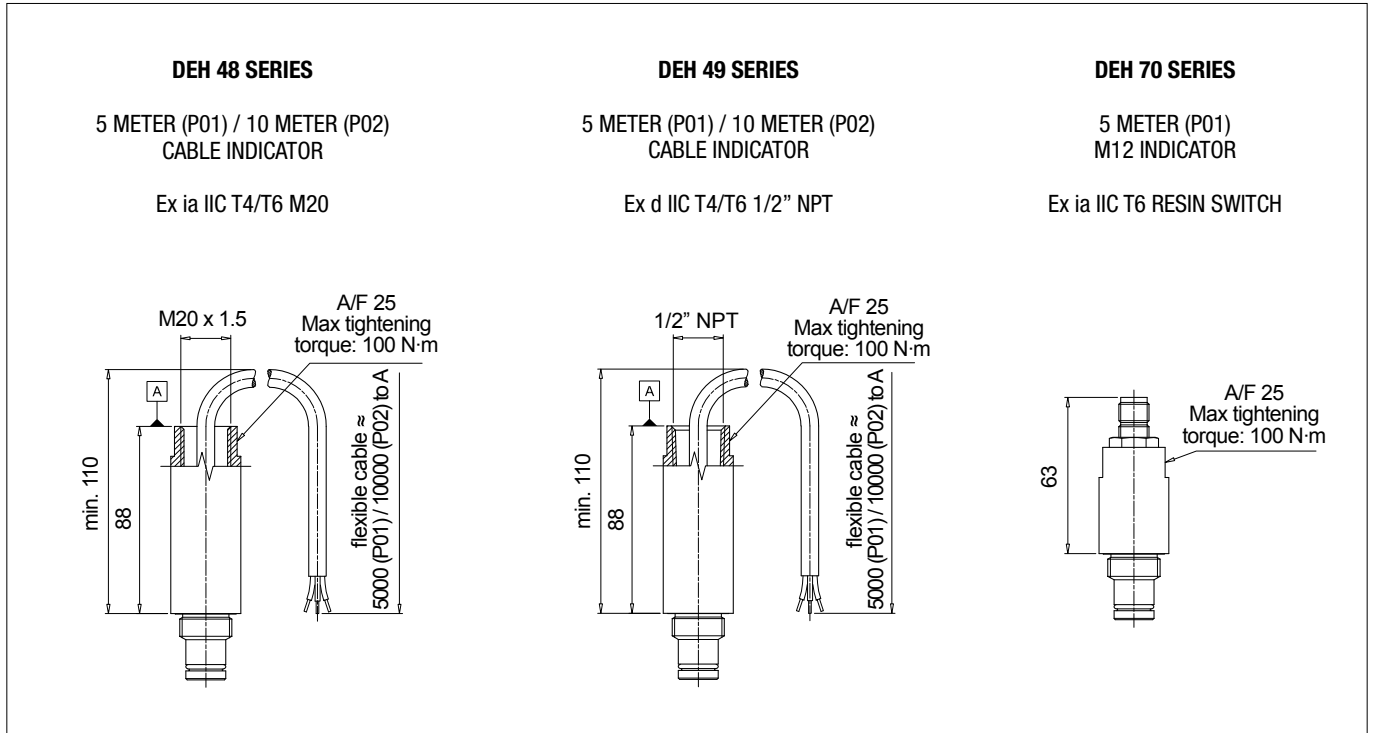

3.3 Designation & Ordering code

ELECTRICAL DIFFERENTIAL INDICATOR - DEH	
Series	Configuration example: DE H 50 F A 70 P01
DE Electrical Differential Indicator	
Pressure Rating	
H 420 bar (6.091 PSI)	
Pressure Setting (*)	
20 2.0 bar	
50 5.0 bar	
70 7.0 bar	
95 10.0 bar	
Seals	
H HNBR	
V FPM	
F MFQ	
Thermostat	
A Without	
Connection	
48 M20 Ex ia IIC T4/T6	
49 1/2" NPT Ex d IIC T4/T6	
70 M12 Ex ia IIC T6	
	Execution
	P01 MP Filtri Standard
	P02 10 meter cable length

(*) Other options available on request

Certification included as standard

TECHNICAL SPECIFICATION

3.4 Wiring diagrams

Wiring instructions are available in section 4.3.

3.5 Temperature Range

For the maximum permissible operating temperature of the indicator, please refer to technical data shown at paragraph 3.1.

If MFQ seals are used on the indicator, the lower temperature threshold must be adjusted to $-40\text{ }^{\circ}\text{C}$ ($-40\text{ }^{\circ}\text{F}$). Surface temperature and/or general heat rise will mainly be generated by the fluid temperature or ambient temperature, as the indicator itself produces minimal heat.

4. Product Installation and Maintenance Instructions

USER INSTRUCTIONS FOR DEH ELECTRICAL INDICATORS

4.1 Correct Usage

The electrical indicator is specifically designed for use with MP Filtri hydraulic pressure and in line filters, the indicator monitors differential pressure across the filter element. The indicators are made up of a certificated switch assembly in a type approved enclosure with a pressure connection that acts on a piston and spring assembly to operate a switch, the movement of this piston is governed by the deferential pressure across the element. The indicators should only ever be used with in the parameters detailed in this manual, the indicator should match or be greater than the system operating pressure.

The purchaser should make the manufacturer aware of any External effects or Aggressive substances that the equipment may be exposed to.

It means that failure to comply with the relevant safety regulations may result in mild injury or property damage.



4.2 Wiring Instructions

DEH 48 SERIES - 5 or 10 METER CABLE INDICATOR Ex ia IIC T4/T6 M20

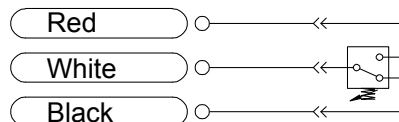

DEH 49 SERIES - 5 or 10 METER CABLE INDICATOR Ex d II T4/T6 1/2" NPT

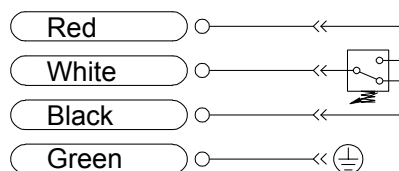

DEH 70 SERIES - IEC 61076-2-101 (M12) INDICATOR Ex ia IIC T6 RESIN SWITCH

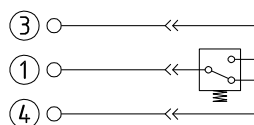

PRODUCT INSTALLATION

4.3 Suitable Operating Fluids

For conductive filtration fluids, the conductivity must be greater than 10-10 S/m. The operating fluids used must be temperature resistant within the limits of the application. The sealing materials used must be resistant in respect of the operating fluids used.

Hydraulic Oils	H to HLPD DIN 51524.
Lubrication Oils	DIN 51517, APJ, ACEA, DIN 51515, ISO 6743.
Compressor Oils	DIN 51506
Rapidly Biodegradable OILS	VDMA 24568, HETG, HEES, HEPG.
Non-Flammable operating fluids	HFA, HFB, HFC & HFD

4.4 Commissioning

The system must only be put into operation once a system engineer has ensured that when the system is operating the permissible surface temperature according to Directive 94/9 EC will not be exceeded. It is also necessary to cross reference the hazardous area coding and check it is suitable for the area it is about to be used in.

Switch on hydraulic system and vent filter at an appropriate point in the system.

Check the indicator for leakage. If any leakage is present, shut the system down and vent any contained pressure. The indicator can then be inspected to check all components are tight. If the unit still leaks then it may be necessary to check the seals on the body by removing the indicator from its cavity. These can then if necessary be replaced in accordance with the spare parts list detailed in section 5.1

Check that the correct indicator is fitted and that it is securely in place. The electrical connection should be checked to see if the wire is held by the cable gland securely and that the gland itself is tight.



4.5 Electrical Connections

Electrical Connections:
Integral cable versions

White - COM
Red - N/O
Black - N/C

Connector Versions:

Pin 1 - COM
Pin 2 - Not used
Pin 3 - N/O
Pin 4 - N/C

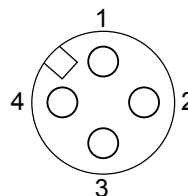

4.6 System requirements Ex ia

The electrical circuit in the hazardous area must be capable of withstanding an ac test voltage of 500v rms to earth or frame of the apparatus for one minute. The power source must be certified by an EEC approved body to Exia or Exib, whichever is applicable. The capacitance and inductance, or inductance to resistance (L/R) ratio of the hazardous area cables must not exceed the value for the power source in use. For cable runs over 2M the following applies $C_i = 120\text{pF/M}$ and $L_i = 0.7\mu\text{H/M}$. Safe area apparatus is unspecified except that it must not be supplied from, nor contain under normal or abnormal conditions, a source of potential with respect to earth in excess of 250 volts rms or 250 volts dc.

Testing

DO NOT USE A "MEGGER" OR BELL TEST SET. USE A SIMPLE LAMP TESTER AS SHOWN OR AN OHM METER OTHERWISE DAMAGE TO THE SWITCH MAY OCCUR.

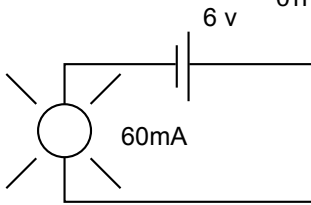

*Testing must be carried out to site regulations.
Do not use above method in hazardous areas.*

5. Related Products

5.1 Spare Parts

Part	Serial Number
HNBR - Upper seal	01068760
HNBR - Lower seal	01030060
FPM - Upper seal	01030046
FPM - Lower seal	01068511
MFQ - Upper seal	01026270
MFQ - Lower seal	01030062

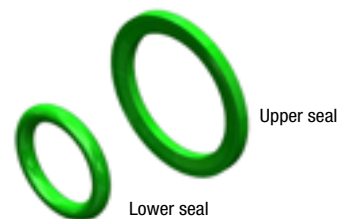
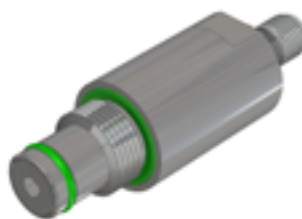
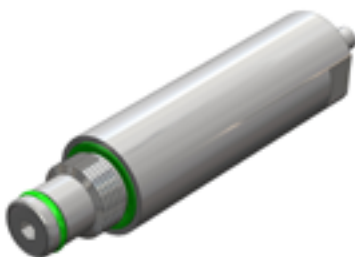

PRODUCT INSTALLATION

6. Reference Certification

IS (Intrinsically Safe) Clogging Indicators are certified as “Simple Apparatus” and are suitable for use in IS circuits when supplied through a certified barrier.

Please observe operating temperature of indicator assembly- the usable range is lower than the certification range of the electrical enclosure



6.1 ATEX

DEH 48 - Ex ia

Certificate Number	Baseefa SGS22ATEX0036X / BAS22UKEX0059X
Manufacturing Standards	EN 60079-0, EN 60079-11
Temp. Range	T4=Tamb -60 °C to +125 °C (from -76 to 257 °F) and T6=Tamb -60 °C to +80 °C (from -76 to 176 °F)
Rating	 II 1 GD Ex ia IIC T6 Ga Ex ia IIC T4 Ga Ex ia IIIC T ₂₀₀ 85 °C Da Ex ia IIIC T ₂₀₀ 135 °C Da

DEH 49 - Ex d

Certificate Number	Baseefa SGS21ATEX0129X / BAS21UKEX0794X
Manufacturing Standards	EN 60079-0, EN 60079-1, EN 60079-31
Temp. Range	T4=Tamb -60 °C to +120 °C (from -76 to 248 °F) and T6=Tamb -60 °C to +70 °C (from -76 to 158 °F)
Rating	 II 2 GD Ex db IIC T6 Gb Ex db IIC T4 Gb Ex tb IIIC T85 °C Db Ex tb IIIC T135 °C Db

DEH 70 - Ex ia

Certificate Number	Baseefa SGS22ATEX0036X / BAS22UKEX0059X
Manufacturing Standards	EN 60079-0, EN 60079-11
Temp. Range	T6=Tamb -60 °C to +80 °C (from -76 to 176 °F)
Rating	 II 1 GD Ex ia IIC T6 Ga Ex ia IIIC T ₂₀₀ 135 °C Da

6.2 IECEx

DEH 48 - Ex ia

Certificate Number	IECEx BAS 22.0026X
Manufacturing Standards	EN 60079-0, EN 60079-11
Temp. Range	T4=Tamb -60 °C to +125 °C (from -76 to 257 °F) and T6=Tamb -60 °C to +80 °C (from -76 to 176 °F)
Rating	 Ex ia IIC T6 Ga Ex ia IIC T4 Ga Ex ia IIIC T ₂₀₀ 85 °C Da Ex ia IIIC T ₂₀₀ 135 °C Da

DEH 49 - Ex d

Certificate Number	IECEx BAS21.0044X
Manufacturing Standards	IEC 60079-0, IEC 60079-1, IEC 60079-31
Temp. Range	T4=Tamb -60 °C to +120 °C (from -76 to 248 °F) and T6=Tamb -60 °C to +70 °C (from -76 to 158 °F)
Rating	 Ex db IIC T6 Gb Ex db IIC T4 Gb Ex tb IIIC T85 °C Db Ex tb IIIC T135 °C Db

DEH 70 - Ex ia

Certificate Number	IECEx BAS 22.0026X
Manufacturing Standards	IEC 60079-0, IEC 60079-11
Temp. Range	From -60 °C to +80 °C (from -76 to 176 °F)
Rating	 Ex ia IIC T6 Ga Ex ia IIIC T ₂₀₀ 135 °C Da

6.3 UL/CSA

DEH 49 Ex d

Certificate Number	E525981
Manufacturing Standards	UL1203 5th Edition and CSA C22.2 No. 30 & No.25
Temp. Range	From -60 °C to +120 °C (from -76 to 248 °F)
Rating	 Class I Div 1 Groups A, B, C, & D Class II Div 1 Groups E, F, & G Class III Hazardous Locations

6.4 EAC TR CU

DEH 48 / DEH 49 / DEH 70

Certificate Number	TC RU C-GBMI062.B.05354
Manufacturing Standards	TP TC 012/2011
Temp. Range	As per ATEX/IECEx Ex d & Ex ia
Rating	 As per ATEX/IECEx Ex d & Ex ia

PRODUCT INSTALLATION

6.5 Conditions of Safe Use of EX ia and EX d

- When used in a dust atmosphere the separately certified cable gland arrangement must maintain the IP6X rating of the enclosure.
- External earth bonding of the stainless steel filter maybe achieved via the filter mounting thread.
- The high pressure versions contain Titanium and must be mounted in such a way as to avoid impact or friction.
- The cable entry to the wireable switch must be fitted with a cable gland which is suitably equipment certified for Ex e and Ex t.
- The process connection thread (where provided) may not meet the flameproof requirements and shall not be used for direct interface with a flameproof enclosures
- The sensor is provided with an internal earth. External earthing is via the cable entry gland or threads.
- 7A Supplementary fuse to be installed on supply lines (for UL/CSA only).
- Supply wires must have a minimum temperature rating of 75 °C (167 °F) (for UL/CSA only).
- Single Seal (for UL/CSA only).

It means that failure to comply with the relevant safety regulations may result in death, serious injury or serious property damage.



6.6 Fatigue Declaration / Identification Statement

Method of fatigue pressure testing conforms to ISO 10771-1, Hydraulic fluid power - Fatigue pressure testing of metal pressure containing envelopes - Part 1: test method.

The DEH range has been tested and approved for a 1million pressure cycle lifetime excluding polymer seals.

Pressure Range	Fatigue Test Declaration
420 bar (6091 psi)	ISO 10771-1 D: DEH 420: 42/0.0 MPa (420/0 bar) (420/0 bar (6091/0psi)): 0.32Hz/310ms: 10 ⁶ Cycles

7. Servicing

7.1 General Information

Servicing and maintenance work should be carried out periodically. The operational safety, longevity, and suitability for use of the indicator all depend on regular and careful maintenance.

7.2 Torque Values

Indicator Body to Cavity

Indicator Pressure Rating	Torque Rating
420 bar (6091 psi)	100 N·m + 10 N·m

7.3 Service Measures

- Spare parts must fulfil the technical requirements that are specified by the manufacturer. This is always guaranteed for original spare parts.
- Keep tools, working area and equipment clean.
- After removing the indicator, clean all parts, check for damage or wear and replace parts if necessary.
- When changing an indicator, it is essential that a high level of cleanliness must be maintained.
- When an indicator is removed the cavity should be covered to prevent contamination.

7.4 Service Intervals

The clogging indicator must be included in the recurrent testing of the electrical system in accordance with EN 60079-17.

7.5 Seal Replacement

If slight or severe leakage is detected from the indicator port, then the elastic seals may need replacing.

The system must be isolated and prepared for maintenance in accordance with Section 4 of this manual.

Once the hydraulic system is deemed safe and the appropriate permissions have been granted, remove the indicator from the filter assembly with a 25 mm spanner. Ensure that the sealing faces are not damaged during the removal process. Remove the existing seals carefully, ensuring the sealing grooves are not damaged. Inspect the sealing faces for damage and ensure they are free from contamination. Replace the seals with those outlined in Section 5.1. Only genuine replacement parts should be used.

The elastic seals should be wetted with clean operating fluid and stretched on for assembly, with care taken not to roll the seals into the grooves. Check the indicator cavity for contamination and clean if necessary. Install the indicator as per Section 4.2.

SERVICING

7.6 Removing the Electrical Differential Indicator

Before any work is commenced, correct authorisation must be obtained from the appropriate responsible person.

Switch off the hydraulic system and release the pressure in the filter or system using the relevant bleed point. (Collect any accumulated fluid in a suitable container and clean or dispose of the fluid in accordance with any local environmental regulations).

Unscrew the clogging indicator using a 25 mm spanner across the flats provided for fitting. Ensure the work area is as clean as possible.

The hydraulic system must only be switched back on once the clogging indicator port has been fitted with either a pressure resistant blanking plug or a suitable clogging indicator.

7.7 Installing the Electrical Differential Indicator

- Lubricate the seal rings and thread on the indicator body, and the port in the filter head, with clean operating fluid.
- Apply thread sealant to the top two threads of the fluid connection. Avoid applying glue to the seals.
- Screw in the indicator using a spanner and tighten to the correct torque
- Switch on the hydraulic system and power supply to the clogging indicator.
- Check the clogging indicator for leakage.
- Vent the filter at an appropriate point.

- The clogging indicator only responds when fluid is flowing through the filter being monitored.
- The clogging indicator may respond during a cold start of the hydraulic system.
- If the clogging indicator responds during a cold start only, it is possible that the element does not need to be changed yet.



CAUTION

Once the indicator is fitted, please refer to the appropriate operators guide/manual for the MP Filtri Stainless Steel Filter.

All data, details and words contained in this publication are provided for use by technically qualified personnel at their discretion, without warranty of any kind.

MP Filtri reserves the right to make modifications to the models and versions of the described products at any time for both technical and/or commercial reasons.

For updated information please visit our website: www.mpfiltri.com

The colors and the pictures of the products are purely indicative.

Any reproduction, partial or total, of this document is strictly forbidden.

All rights are strictly reserved

WORLDWIDE NETWORK

CANADA ♦ CHINA ♦ FRANCE ♦ GERMANY ♦ INDIA ♦ SINGAPORE
UNITED ARAB EMIRATES ♦ UNITED KINGDOM ♦ USA



PASSION  PERFORM

in   



mpfiltri.com

Scan or click me!

MP Filtri reserves the right to make modifications to the models and versions of the described products at any time for both technical and/or commercial reasons. For updated information please visit our website: www.mpfiltri.com. The colors and the pictures of the products are purely indicative. Any reproduction, partial or total, of this document is strictly forbidden. All rights are strictly reserved.

201.037_05
MF01000065
EN - 2026.03