

RETURN / SUCTION FILTERS

HYDRAULIC
FILTRATION

CATALOGUE



MPFILTRI[®]

PASSION **T** PERFORM

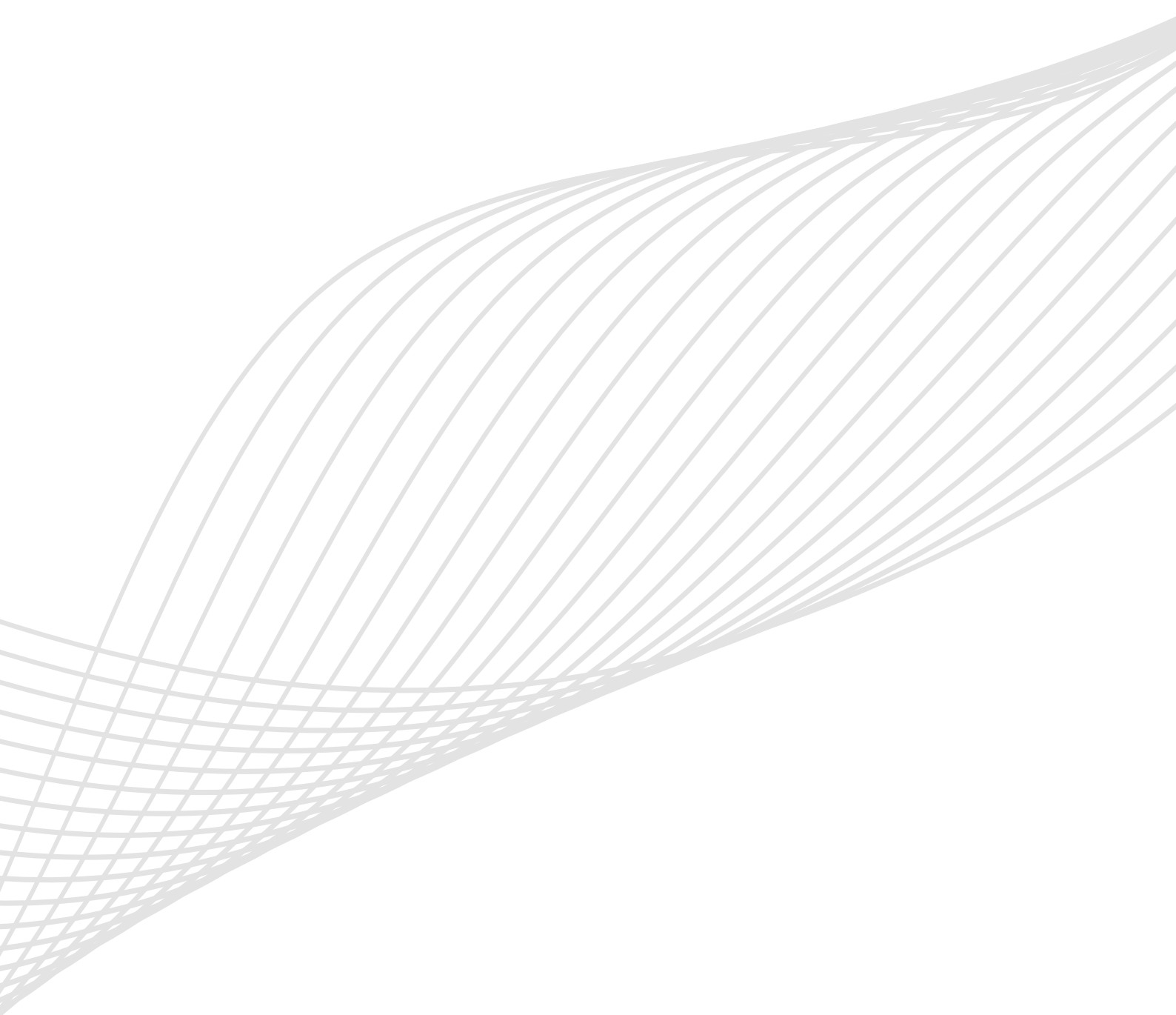

CONTAMINATION MANAGEMENT

INDEX

	Page
① HYDRAULIC FLUIDS	12
② FLUIDS CONTAMINATION	12
③ FLUIDS COMPATIBILITY CHART	12
④ EFFECTS OF CONTAMINATION ON HYDRAULIC COMPONENTS	13
⑤ MEASURING THE SOLID CONTAMINATION LEVEL	13
⑥ FILTRATION TECHNOLOGIES	16
⑦ RECOMMENDED CONTAMINATION CLASSES	17
⑧ TYPES OF FILTERS	17
⑨ FILTER SIZING PARAMETERS	18
⑩ APPLICABLE STANDARDS FOR FILTER DEVELOPMENT	18
⑪ WATER IN HYDRAULIC AND LUBRICATING FLUIDS	19
⑫ THE ANTI-STATIC FILTERS zerospark+	20

1 HYDRAULIC FLUIDS

The fluid is the vector that transmits power, energy within an oleodynamic circuit. In addition to transmitting energy through the circuit, it also performs additional functions such as lubrication, protection and cooling of the surfaces.

The classification of fluids used in hydraulic systems is coded in many regulatory references, different Standards.

The most important classification system for hydraulic fluids is the one defined by International Organization for Standardization (ISO), which established a classification system within their standard: "ISO 6743-4 Lubricants, Industrial Oils and Related Products". In particular, the parts of interest for hydraulic fluids are:

- Lubricants, industrial oils and related products (class L)
- Classifications - Part 4L - Family H (Hydraulic systems)

The ISO 6743-4 classification system can be generally applied to the three primary classes of hydraulic fluids:

- Mineral Oils (i.e.: petroleum) Hydraulic Fluids (i.e.: HH: Mineral lubricants without corrosion inhibitors; HL: HH-type lubricants with oxidation reduction and anticorrosive additives; HM: HL-type lubricants with anti-wear additives; HV: HM-type lubricants with a higher viscosity grade and temperature properties; and others).
- Biodegradable Hydraulic Fluids (HExx), also defined as "Environmentally acceptable hydraulic fluids".
- Fire Resistant Hydraulic Fluids (HFxx), which could be further split into: Fire-resistant aqueous fluids (HFAx, HFB; HFC) ; Fire-resistant synthetic anhydrous fluids (HFDx).

The choice of fluid for an hydraulic system must take into account several parameters.

These parameters can adversely affect the performance of an hydraulic system, causing delay in the controls, pump cavitation, excessive absorption, excessive temperature rise, efficiency reduction, increased drainage, wear, jam/block or air intake in the plant.

The main properties that characterize hydraulic fluids and affect their choice are:

- **DYNAMIC VISCOSITY**
It identifies the fluid's resistance to sliding due to the impact of the particles forming it.
- **KINEMATIC VISCOSITY**
It is a widespread formal dimension in the hydraulic field.
It is calculated with the ratio between the dynamic viscosity and the fluid density.
Kinematic viscosity varies with temperature and pressure variations.
- **VISCOSITY INDEX**
This value expresses the ability of a fluid to maintain viscosity when the temperature changes.
A high viscosity index indicates the fluid's ability to limit viscosity variations by varying the temperature.
- **FILTERABILITY INDEX**
It is the value that indicates the ability of a fluid to cross the filter materials.
A low filterability index could cause premature clogging of the filter material.
- **WORKING TEMPERATURE**
Working temperature affects the fundamental characteristics of the fluid.
As already seen, some fluid characteristics, such as cinematic viscosity, vary with the temperature variation.

When choosing a hydraulic oil, must therefore be taken into account of the environmental conditions in which the machine will operate.

- **COMPRESSIBILITY MODULE**
Every fluid subjected to a pressure contracts, increasing its density.
The compressibility module identifies the increase in pressure required to cause a corresponding increase in density.
- **HYDROLYTIC STABILITY**
It is the characteristic that prevents galvanic pairs that can cause wear in the plant/system.
- **ANTIOXIDANT STABILITY AND WEAR PROTECTION**
These features translate into the capacity of a hydraulic oil to avoid corrosion of metal elements inside the system.
- **HEAT TRANSFER CAPACITY**
It is the characteristic that indicates the capacity of hydraulic oil to exchange heat with the surfaces and then cool them.

2 FLUID CONTAMINATION

Whatever the nature and properties of fluids, they are inevitably subject to contamination. Fluid contamination can have two origins:

- **INITIAL CONTAMINATION**
Caused by the introduction of contaminated fluid into the circuit, or by incorrect storage, transport or transfer operations.
- **PROGRESSIVE CONTAMINATION**
Caused by factors related to the operation of the system, such as metal surface wear, sealing wear, oxidation or degradation of the fluid, the introduction of contaminants during maintenance, corrosion due to chemical or electrochemical action between fluid and components, cavitation.
The contamination of hydraulic systems can be of different nature:
- **SOLID CONTAMINATION**
For example rust, slag, metal particles, fibers, rubber particles, paint particles or additives
- **LIQUID CONTAMINATION**
For example, the presence of water due to condensation or external infiltration or acids
- **GASEOUS CONTAMINATION**
For example, the presence of air due to inadequate oil level in the tank, drainage in suction ducts, incorrect sizing of tubes or tanks.

3 FLUID COMPATIBILITY CHARTS

For more detailed information on specific fluid compatibility please refer to the fluid compatibility charts on our website:



Scan or click me!

④ EFFECTS OF CONTAMINATION ON HYDRAULIC COMPONENTS

Solid contamination is recognized as the main cause of malfunction, failure and early degradation in hydraulic systems. It is impossible to delete it completely, but it can be effectively controlled by appropriate devices.

CONTAMINATION IN PRESENCE OF LARGE TOLERANCES



CONTAMINATION IN PRESENCE OF NARROW TOLERANCES

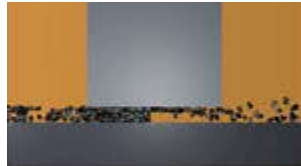

Solid contamination mainly causes surface damage and component wear.

- ABRASION OF SURFACES
Cause of leakage through mechanical seals, reduction of system performance, failures.
- SURFACE EROSION
Cause of leakage through mechanical seals, reduction of system performance, variation in adjustment of control components, failures.
- ADHESION OF MOVING PARTS
Cause of failure due to lack of lubrication.
- DAMAGES DUE TO FATIGUE
Cause of breakdowns and components breakdown.

ABRASION



EROSION



ADHESION



FATIGUE



Liquid contamination mainly results in decay of lubrication performance and protection of fluid surfaces.

DISSOLVED WATER

- INCREASING FLUID ACIDITY
Cause of surface corrosion and premature fluid oxidation
- GALVANIC COUPLE AT HIGH TEMPERATURES
Cause of corrosion

FREE WATER - ADDITIONAL EFFECTS

- DECAY OF LUBRICANT PERFORMANCE
Cause of rust and sludge formation, metal corrosion and increased solid contamination
- BATTERY COLONY CREATION
Cause of worsening in the filterability feature

- ICE CREATION AT LOW TEMPERATURES
Cause damage to the surface
- ADDITIVE DEPLETION
Free water retains polar additives

Gaseous contamination mainly results in decay of system performance.

- CUSHION SUSPENSION
Cause of increased noise and cavitation.
- FLUID OXIDATION
Cause of corrosion acceleration of metal parts.
- MODIFICATION OF FLUID PROPERTIES (COMPRESSIBILITY MODULE, DENSITY, VISCOSITY)
Cause of system's reduction of efficiency and of control. It is easy to understand how a system without proper contamination management is subject to higher costs than a system that is provided.
- MAINTENANCE
Increase maintenance activities, spare parts, machine stop costs.
- ENERGY AND EFFICIENCY
Efficiency and performance reduction due to friction, drainage, cavitation.

⑤ MEASURING THE SOLID CONTAMINATION LEVEL

The level of contamination of a system identifies the amount of contaminant contained in a fluid. This parameter refers to a unit volume of fluid. The level of contamination may be different at different points in the system. From the information in the previous paragraphs it is also apparent that the level of contamination is heavily influenced by the working conditions of the system, by its working years and by the environmental conditions.

What is the size of the contaminating particles that we must handle in our hydraulic circuit?

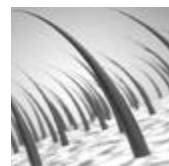

HUMAN HAIR (75 µm)

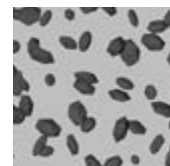

MINIMUM DIMENSION VISIBLE WITH HUMAN EYES (40 µm)

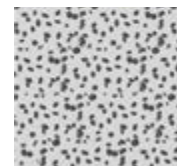

TYPICAL CONTAMINANT DIMENSION IN A HYDRAULIC CIRCUIT (4 - 14 µm)

Contamination level analysis is significant only if performed with a uniform and repeatable method, conducted with standard test methods and suitably calibrated equipment. To this end, ISO has issued a set of standards that allow tests to be conducted and express the measured values in the following ways.

- GRAVIMETRIC LEVEL - ISO 4405

The level of contamination is defined by checking the weight of particles collected by a laboratory membrane. The membrane must be cleaned, dried and desiccated, with fluid and conditions defined by the Standard. The volume of fluid is filtered through the membrane by using a suitable suction system. The weight of the contaminant is determined by checking the weight of the membrane before and after the fluid filtration.



CLEAN MEMBRANE



CONTAMINATED MEMBRANE

CONTAMINATION MANAGEMENT

- CUMULATIVE DISTRIBUTION OF THE PARTICLES SIZE - ISO 4406

The level of contamination is defined by counting the number of particles of certain dimensions per unit of volume of fluid. Measurement is performed by Contamination Monitoring Products (CMP).

Following the count, the contamination classes are determined, corresponding to the number of particles detected in the unit of fluid.

The most common classification methods follow ISO 4406 and SAE AS 4059 (Aerospace Sector) regulations.

NAS 1638 is still used although obsolete.

Classification example according to ISO 4406

The International Standards Organization standard ISO 4406 is the preferred method of quoting the number of solid contaminant particles in a sample. The level of contamination is defined by counting the number of particles of certain dimensions per unit of volume of fluid. The measurement is performed by Contamination Monitoring Products (CMP).

The numbers represent a code which identifies the number of particles of certain sizes in 1ml of fluid. Each code number has a particular size range. The first scale number represents the number of particles equal to or larger than 4 $\mu\text{m}_{(c)}$ per millilitre of fluid; The second scale number represents the number of particles equal to or larger than 6 $\mu\text{m}_{(c)}$ per millilitre of fluid; The third scale number represents the number of particles equal to or larger than 14 $\mu\text{m}_{(c)}$ per millilitre of fluid.

ISO 4406 - Allocation of Scale Numbers

Class	Number of particles per ml	
	Over	Up to
28	1 300 000	2 500 000
27	640 000	1 300 000
26	320 000	640 000
25	160 000	320 000
24	80 000	160 000
23	40 000	80 000
22	20 000	40 000
21	10 000	20 000
20	5 000	10 000
19	2 500	5 000
18	1 300	2 500
17	640	1 300
16	320	640
15	160	320
14	80	160
13	40	80
12	20	40
11	10	20
10	5	10
9	2.5	5
8	1.3	2.5
7	0.64	1.3
6	0.32	0.64
5	0.16	0.32
4	0.08	0.16
3	0.04	0.08
2	0.02	0.04
1	0.01	0.02
0	0	0.01

- > 4 $\mu\text{m}_{(c)}$ = 350 particles
 - > 6 $\mu\text{m}_{(c)}$ = 100 particles
 - > 14 $\mu\text{m}_{(c)}$ = 25 particles
- 16 / 14 / 12

ISO 4406 Cleanliness Code System

Microscope counting examines the particles differently to Contamination Monitoring Products (CMP) and the code is given with two scale numbers only. These are at 5 μm and 15 μm equivalent to the 6 $\mu\text{m}_{(c)}$ and 14 $\mu\text{m}_{(c)}$ of Contamination Monitoring Products (CMP).

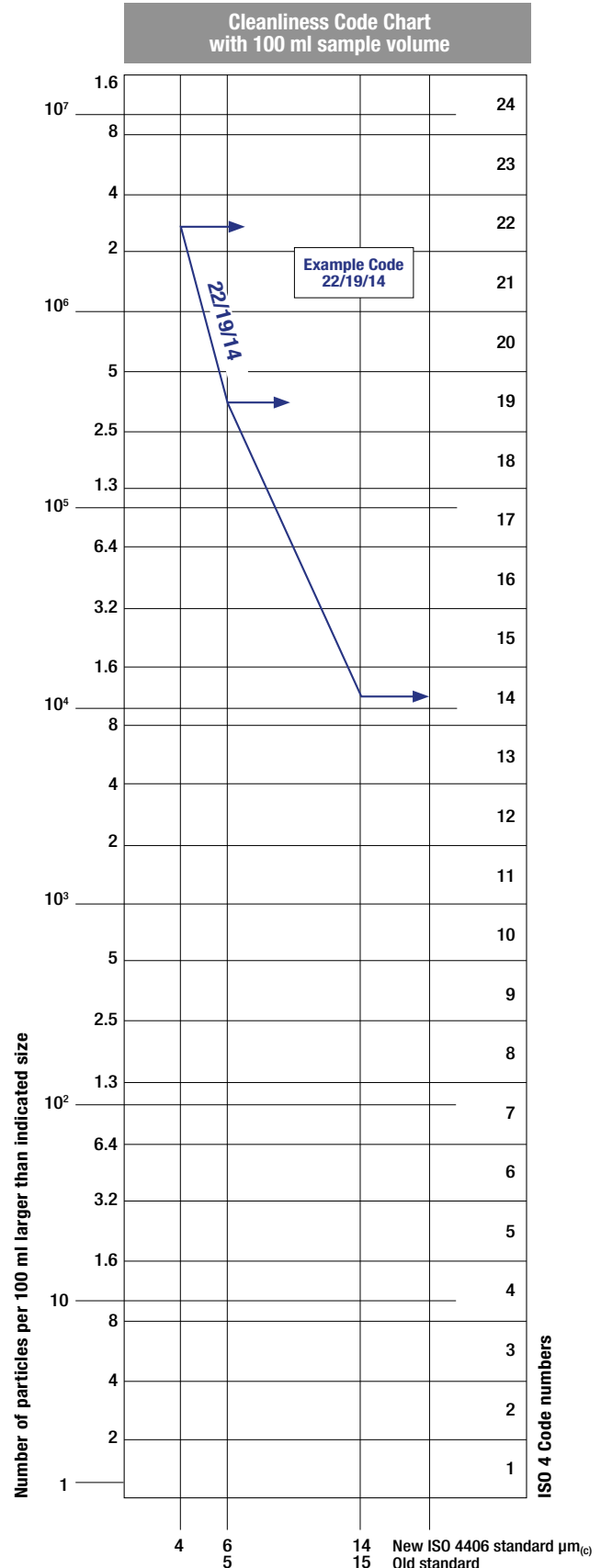

- CUMULATIVE DISTRIBUTION OF THE PARTICLES SIZE
SAE AS4059-1 and SAE AS4059-2

Classification example according to SAE AS4059 - Rev. G

The code, prepared for the aerospace industry, is based on the size, quantity, and particle spacing in a 100 ml fluid sample. The contamination classes are defined by numeric codes, the size of the contaminant is identified by letters (A-F).

This SAE Aerospace Standard (AS) defines cleanliness levels for particulate contamination of hydraulic fluids and includes methods of reporting data relating to the contamination levels. Tables 1 and 2 below provide differential and cumulative particle counts respectively for counts obtained by an automatic particle counter, e.g. LPA3.

Table 1 - Class for differential measurement

Class	Dimension of contaminant Maximum Contamination Limits per 100 ml (3)				
	5-15 µm	15-25 µm	25-50 µm	50-100 µm	>100 µm (1)
	6-14 µm(c)	14-21 µm(c)	21-38 µm(c)	38-70 µm(c)	>70 µm(c) (2)
00	125	22	4	1	0
0	250	44	8	2	0
1	500	89	16	3	1
2	1 000	178	32	6	1
3	2 000	356	63	11	2
4	4 000	712	126	22	4
5	8 000	1 425	253	45	8
6	16 000	2 850	506	90	16
7	32 000	5 700	1 012	180	32
8	64 000	11 400	2 025	360	64
9	128 000	22 800	4 050	720	128
10	256 000	45 600	8 100	1 440	256
11	512 000	91 200	16 200	2 880	512
12	1 024 000	182 400	32 400	5 760	1 024

6 - 14 µm(c) = 15 000 particles
14 - 21 µm(c) = 2 200 particles
21 - 38 µm(c) = 200 particles
38 - 70 µm(c) = 35 particles
> 70 µm(c) = 3 particles
SAE AS4059 REV G - Class 6

(1) Size range, optical microscope, based on longest dimension as measured per AS598 or ISO 4407. (2) Size range CMP calibrated per ISO 11171 or an optical or electron microscope with image analysis software, based on projected area equivalent diameter. (3) Contamination classes and particle count limits are identical to NAS 1638.

Table 2 - Class for cumulative measurement

Class	Dimension of contaminant Maximum Contamination Limits per 100 ml					
	>1 µm	>5 µm	>15 µm	>25 µm	>50 µm	>100 µm (1)
	>4 µm(c)	>6 µm(c)	>14 µm(c)	>21 µm(c)	>38 µm(c)	>70 µm(c) (2)
000	195	76	14	3	1	0
00	390	152	27	5	1	0
0	780	304	54	10	2	0
1	1 560	609	109	20	4	1
2	3 120	1 217	217	39	7	1
3	6 250	2 432	432	76	13	2
4	12 500	4 864	864	152	26	4
5	25 000	9 731	1 731	306	53	8
6	50 000	19 462	3 462	612	106	16
7	100 000	38 924	6 924	1 224	212	32
8	200 000	77 849	13 849	2 449	424	64
9	400 000	155 698	27 698	4 898	848	128
10	800 000	311 396	55 396	9 796	1 696	256
11	1 600 000	622 792	110 792	19 592	3 392	512
12	3 200 000	1 245 584	221 584	39 184	6 784	1 024

> 4 µm(c) = 45 000 particles
> 6 µm(c) = 15 000 particles
> 14 µm(c) = 1 500 particles
> 21 µm(c) = 250 particles
> 38 µm(c) = 15 particles
> 70 µm(c) = 3 particles
SAE AS4059 REV G cpc* Class 6 6/6/5/5/4/2

* cumulative particle count

(1) Size range, optical microscope, based on longest dimension as measured per AS598 or ISO 4407. (2) Size range, CMP calibrated per ISO 11171 or an optical or electron microscope with image analysis software, based on projected area equivalent diameter. (3) Contamination classes and particle count limits are identical to NAS 1638.

- CLASSES OF CONTAMINATION ACCORDING TO NAS 1638 (January 1964)

The NAS system was originally developed in 1964 to define contamination classes for the contamination contained within aircraft components.

The application of this standard was extended to industrial hydraulic systems simply because nothing else existed at the time.

The coding system defines the maximum numbers permitted of 100 ml volume at various size intervals (differential counts) rather than using cumulative counts as in ISO 4406. Although there is no guidance given in the standard on how to quote the levels, most industrial users quote a single code which is the highest recorded in all sizes and this convention is used on MP Filtri Contamination Monitoring Products (CMP).

The contamination classes are defined by a number (from 00 to 12) which indicates the maximum number of particles per 100 ml, counted on a differential basis, in a given size bracket.

Size Range Classes (in microns)

Class	Maximum Contamination Limits per 100 ml				
	5-15	15-25	25-50	50-100	>100
	5-15 µm	15-25 µm	25-50 µm	50-100 µm	>100 µm
00	125	22	4	1	0
0	250	44	8	2	0
1	500	89	16	3	1
2	1 000	178	32	6	1
3	2 000	356	63	11	2
4	4 000	712	126	22	4
5	8 000	1 425	253	45	8
6	16 000	2 850	506	90	16
7	32 000	5 700	1 012	180	32
8	64 000	11 400	2 025	360	64
9	128 000	22 800	4 050	720	128
10	256 000	45 600	8 100	1 440	256
11	512 000	91 200	16 200	2 880	512
12	1 024 000	182 400	32 400	5 760	1 024

5-15 µm = 42 000 particles
15-25 µm = 2 200 particles
25-50 µm = 150 particles
50-100 µm = 18 particles
> 100 µm = 3 particles
Class NAS 8

- CUMULATIVE DISTRIBUTION OF THE PARTICLES SIZE - ISO 4407

The level of contamination is defined by counting the number of particles collected by a laboratory membrane per unit of fluid volume. The measurement is done by a microscope. The membrane must be cleaned, dried and desiccated, with fluid and conditions defined by the Standard. The fluid volume is filtered through the membrane, using a suitable suction system.

The level of contamination is identified by dividing the membrane into a predefined number of areas and by counting the contaminant particles using a suitable laboratory microscope.

MICROSCOPE CONTROL AND MEASUREMENT



Example figure 1 and 2

COMPARISON PHOTOGRAPH'S
1 graduation = 10µm



Fig. 1



Fig. 2



For other comparison photographs for contamination classes see the "Filtration and Particle Analyser Handbook".

Scan or click me!

CONTAMINATION MANAGEMENT

- CLEANLINESS CODE COMPARISON

Although ISO 4406 standard is being used extensively within the hydraulics industry other standards are occasionally required and a comparison may be requested. The table below gives a very general comparison but often no direct comparison is possible due to the different classes and sizes involved.

ISO 4406	SAE AS4059 Table 2	SAE AS4059 Table 1	NAS 1638
> 4 $\mu\text{m}_{(c)}$ 6 $\mu\text{m}_{(c)}$ 14 $\mu\text{m}_{(c)}$	> 4 $\mu\text{m}_{(c)}$ 6 $\mu\text{m}_{(c)}$ 14 $\mu\text{m}_{(c)}$	4-6 6-14 14-21 21-38 38-70 >70	5-15 15-25 25-50 50-100 >100
23 / 21 / 18	13A / 12B / 12C	12	12
22 / 20 / 17	12A / 11B / 11C	11	11
21 / 19 / 16	11A / 10B / 10C	10	10
20 / 18 / 15	10A / 9B / 9B	9	9
19 / 17 / 14	9A / 8B / 8C	8	8
18 / 16 / 13	8A / 7B / 7C	7	7
17 / 15 / 12	7A / 6B / 6C	6	6
16 / 14 / 11	6A / 5B / 5C	5	5
15 / 13 / 10	5A / 4B / 4C	4	4
14 / 12 / 09	4A / 3B / 3C	3	3

6 FILTRATION TECHNOLOGIES

Various mechanisms such as mechanical stoppage, magnetism, gravimetric deposit, or centrifugal separation can be used to reduce the level of contamination.

The mechanical stoppage method is most effective and can take place in two ways:

- SURFACE FILTRATION

It is by direct interception. The filter prevents particles larger than the pores from continuing in the plant / system. Surface filters are generally manufactured with metal canvases or meshes.

- DEPTH FILTERING

Filters are constructed by fiber interlacing. Such wraps form pathways of different shapes and sizes in which the particles remain trapped when they find smaller apertures than their diameter.

Depth filters are generally produced with papers impregnated with phenolic resins, metal fibers or inorganic fibers.

In inorganic fiber filtration, commonly called microfibre, the filtering layers are often overlapped in order to increase the ability to retain the contaminant.

WIRE MESH FILTRATION

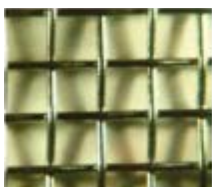

PAPER FILTRATION



MICROFIBER FILTRATION

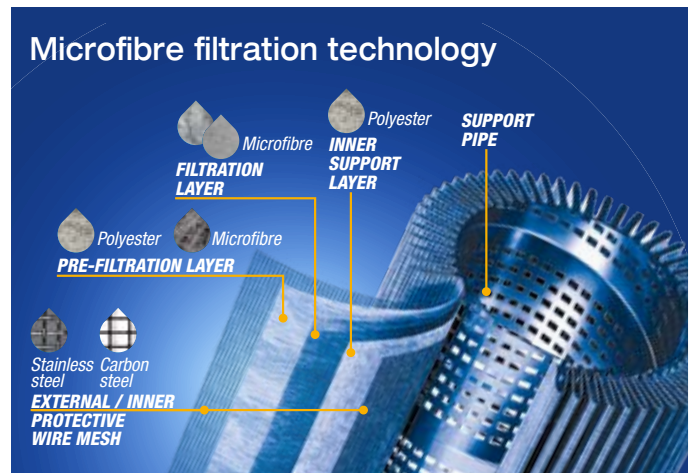

The filtration efficiency of metallic mesh filtrations is defined as the maximum particle size that can pass through the meshes of the filtering grid.

The efficiency of microfibre and paper filtration ($\beta_{x(c)}$) is defined through a lab test called Multipass Test. The efficiency value ($\beta_{x(c)}$) is defined as the ratio between the number of particles of certain dimensions detected upstream and downstream of the filter.

$$\frac{\text{Upstream particles number} > X \mu\text{m}_{(c)}}{\text{Downstream particles number} > X \mu\text{m}_{(c)}} = \beta_{x(c)}$$



Value ($\beta_{x(c)}$)	2	10	75	100	200	1000
Efficiency	50%	90%	98.7%	99%	99.5%	99.9%

Test conditions, such as type of fluid to be used (MIL-H-5606), type of contaminant to be used (ISO MTD), fluid viscosity, test temperature, are determined by ISO 16889.

In addition to the filtration efficiency value during the Multipass test, other important features, such as filtration stability (β stability) and dirt holding capacity (DHC), are also tested.

Poor filtration stability is the cause of the filtering quality worsening as the filter life rises. Low dirt holding capacity causes a reduction in the life of the filter.

Filtration ISO Standard Comparison

$\beta_{x(c)} > 1000$ ISO 16889	$\beta_x > 200$ ISO 4572	MP Filtri Filter media code
5 $\mu\text{m}_{(c)}$	3 μm	A03
7 $\mu\text{m}_{(c)}$	6 μm	A06
10 $\mu\text{m}_{(c)}$	10 μm	A10
16 $\mu\text{m}_{(c)}$	18 μm	A16
21 $\mu\text{m}_{(c)}$	25 μm	A25

7 RECOMMENDED CONTAMINATION CLASSES

Any are the nature and the properties of fluids, they are inevitably subject to contamination. The level of contamination can be managed by using special components called filters.

Hydraulic components builders, knowing the problem of contamination, recommend the filtration level appropriate to the use of their products.

Example of recommended contamination levels for pressures below 140 bar.

Piston pumps with fixed flow rate	•					
Piston pumps with variable flow rate			•			
Vane pumps with fixed flow rate		•				
Vane pumps with variable flow			•			
Engines	•					
Hydraulic cylinders	•					
Actuators					•	
Test benches						•
Check valve	•					
Directional valves	•					
Flow regulating valves	•					
Proportional valves				•		
Servo-valves					•	
Flat bearings			•			
Ball bearings				•		
ISO 4406 CODE	20/18/15	19/17/14	18/16/13	17/15/12	16/14/11	15/13/10
Recommended filtration $\beta_{x(c)} \geq 1.000$	$\beta_{21(c)} > 1000$	$\beta_{15(c)} > 1000$	$\beta_{10(c)} > 1000$	$\beta_{7(c)} > 1000$	$\beta_{7(c)} > 1000$	$\beta_{5(c)} > 1000$
MP Filtri media code	A25	A16	A10	A06	A06	A03

The common classification of filters is determined by their position in the plant.

8 TYPES OF FILTERS

Suction filters

They are positioned before the pump and are responsible for protecting the pump from dirty contaminants. It also provides additional flow guidance to the pump suction line.

Being subject to negligible working pressures are manufactured with simple and lightweight construction.

They are mainly produced with gross grade surface filtrations, mainly $60 \div 125 \mu\text{m}$.

They can be equipped with a magnetic filter for retaining ferrous particles.

They are generally placed under the fluid head to take advantage of the piezometric thrust of the fluid and reduce the risk of cavitation.

There are two types of suction filters:

- IMMERSION FILTERS

Simple filter element screwed on the suction pipe

- FILTERS WITH CONTAINER

Container filters that are more bulky, but provide easier maintenance of the tank

Delivery (or Pressure) filters

They are positioned between the pump and most sensitive regulating and controlling components, such as servo valves or proportional valves, and are designed to ensure the class of contamination required by the components used in the circuit.

Being subjected to high working pressures are manufactured with more robust and articulated construction. In particular situations of corrosive environments or aggressive fluids can be made of stainless steel.

They are mainly produced with filtering depths of $3 \div 25 \mu\text{m}$.

They can be manufactured with in-line connections, with plate or flange connections or directly integrated into the circuit control blocks / manifolds.

They can also be manufactured in duplex configuration to allow the contaminated section to be maintained even when the plant / system is in operation without interruption of the working cycle.

Return filters

They are positioned on the return line to the tank and perform the task of filtering the fluid from particles entering the system from the outside or generated by the wear of the components.

They are generally fixed to the reservoir (for this reason also called top tank mounted), positioned semi-immersed or completely immersed.

The positioning of the return filters must guarantee in all operating conditions that the fluid drainage takes place in immersed condition; this is to avoid creating foams in the tank that can cause malfunctions or cavitation in the pumps.

For the sizing of the return filters, account must be taken of the presence of accumulators or cylinders that can make the return flow considerably greater than the pump suction flow rate.

Being subject to contained working pressures are manufactured with simple and lightweight construction.

Normally it is possible to extract the filter element without disconnecting the filter from the rest of the system.

Combined filters

They are designed to be applied to systems with two or more circuits. They are commonly used in hydrostatic transmission machines where they have a dual filtration function of the return line and suction line of the hydrostatic transmission pump.

The filter is equipped with a valve that keeps the 0.5 bar pressure inside the filter. A portion of the fluid that returns to the tank is filtered by the return filter element, generally produced with absolute filtration, and returns to the transmission booster pump.

Only excess fluid returns to the tank through the valve.

The internal pressure of the filter and the absolute filtration help to avoid the cavitation phenomenon inside the pump.

Off-line filters

They are generally used in very large systems / plants, placed in a closed circuit independent from the main circuit. They remain in operation regardless of the operation of the main circuit and are crossed by a constant flow rate.

They can also be manufactured in duplex configuration to allow the contaminated section to be maintained even when the unit is in operation without interruption of the work cycle.

Venting filters

During the operation of the plants, the fluid level present in the reservoir changes continuously.

The result of this continuous fluctuation is an exchange of air with the outside environment.

The venting filter function, positioned on the tank, is to filter the air that enters the tank to compensate for fluid level variations.

9 FILTER SIZING PARAMETERS

The choice of the filter system for an hydraulic system is influenced by several factors.

It is necessary to consider the characteristics of the various components present in the plant and their sensitivity to contamination.

It is also necessary to consider all the tasks that the filter will have to do within the plant:

- FLUID PROTECTION FROM CONTAMINATION
- PROTECTION OF OLEODYNAMIC COMPONENTS SENSITIVE TO CONTAMINATION
- PROTECTION OF OLEODYNAMIC PLANTS FROM ENVIRONMENTAL WASTE
- PROTECTION OF OLEODYNAMIC PLANTS FROM CONTAMINATION CAUSED BY COMPONENTS' FAILURES

The advantages of proper positioning and sizing of the filters are

- MORE RELIABILITY OF THE SYSTEM
- LONGER LIFE OF THE FLUID COMPONENTS
- REDUCTION OF STOP TIME
- REDUCTION OF FAILURE CASUALTIES

Each hydraulic filter is described by general features that identify the possibility of use in different applications.

- **MAXIMUM WORKING PRESSURE (P_{max})**

The maximum working pressure of the filter must be greater than or equal to the pressure of the circuit section in which it will be installed.

- **PRESSURE DROP (ΔP)**

The pressure drop depends on a number of factors, such as the working circuit temperature, the fluid viscosity, the filter element cleaning condition.

- **WORKING TEMPERATURE (T)**

The working temperature deeply affect the choice of materials. Excessively high or low temperatures may adversely affect the strength of the materials or the characteristics of the seals.

- **FILTRATION EFFICIENCY (%) / FILTRATION RATIO ($\beta_{x(c)}$)**

Filtration efficiency is the most important parameter to consider when selecting a filter.

When choosing the filtration performances, the needs of the most sensitive components in the system must be considered.

- **FLUID TYPE**

The type of fluid influences the choice of filters in terms of compatibility and viscosity. It is always mandatory to check the filterability.

- **PLACEMENT IN THE PLANT**

The position of the filter in the system conditions the efficiency of all filter performances.

10 APPLICABLE STANDARDS FOR FILTER DEVELOPMENT

In order to obtain unique criteria for development and verification of the filters performance, specific regulations for the filters and filter elements testing have been issued by ISO. These norms describe the target, the methodology, the conditions and the presentation methods for the test results.

ISO 2941

Hydraulic fluid power -- Filter elements -- Verification of collapse/burst pressure rating

This Standard describes the method for testing the collapse / burst resistance of the filter elements.

The test is performed by crossing the contaminated fluid filter element at a predefined flow rate. The progressive clogging of the filter element, determined by contamination, causes an increase in differential pressure.

ISO 2942

Hydraulic fluid power -- Filter elements -- Verification of fabrication integrity and determination of the first bubble point

This Standard describes the method to verify the integrity of the assembled filter elements.

It can be used to verify the quality of the production process or the quality of the materials by verifying the pressure value of the first bubble point.

ISO 2943

Hydraulic fluid power -- Filter elements -- Verification of material compatibility with fluids

This Standard describes the method to verify the compatibility of materials with certain hydraulic fluids.

The test is carried out by keeping the element (the material sample) immersed in the fluid under high or low temperature conditions for a given period of time and verifying the retention of the characteristics.

ISO 3723

Hydraulic fluid power -- Filter elements -- Method for end load test

This Standard describes the method for verifying the axial load resistance of the filter elements.

After performing the procedure described in ISO 2943, the designed axial load is applied to the filter element. To verify the test results, then the test described in ISO 2941 is performed.

ISO 3968

Hydraulic fluid power -- Filters -- Evaluation of differential pressure versus flow characteristics

This Standard describes the method for checking the pressure drop across the filter.

The test is carried out by crossing the filter from a given fluid and by detecting upstream and downstream pressures.

Some of the parameters defined by the Standard are the fluid, the test temperature, the size of the tubes, the position of the pressure detection points.

ISO 16889

Hydraulic fluid power -- Filters -- Multi-pass method for evaluating filtration performance of a filter element

This Standard describes the method to check the filtration characteristics of the filter elements.

The test is performed by constant introduction of contaminant (ISO MTD). The characteristics observed during the test are the filtration efficiency and the dirty holding capacity related to the differential pressure.

ISO 23181

Hydraulic fluid power -- Filter elements -- Determination of resistance to flow fatigue using high viscosity fluid

This Standard describes the method for testing the fatigue resistance of the filter elements. The test is carried out by subjecting the filter to continuous flow variations, thus differential pressure, using a high viscosity fluid.

ISO 11170

Hydraulic fluid power -- Sequence of tests for verifying performance characteristics of filter elements

The Standard describes the method for testing the performance of filter elements. The protocol described by the regulations provides the sequence of all the tests described above in order to verify all the working characteristics (mechanical, hydraulic and filtration).

ISO 10771-1

Hydraulic fluid power -- Fatigue pressure testing of metal pressure-containing envelopes -- Test method

This Standard describes the method to check the resistance of the hydraulic components with pulsing pressure.

It can be applied to all metal components (excluding tubes) subject to cyclic pressure used in the hydraulic field.

11 WATER IN HYDRAULIC AND LUBRICATING FLUIDS

Water Content

In mineral oils and non aqueous resistant fluids water is undesirable. Mineral oil usually has a water content of 50-300 ppm (@40°C) which it can support without adverse consequences.

Once the water content exceeds about 300ppm the oil starts to appear hazy. Above this level there is a danger of free water accumulating in the system in areas of low flow. This can lead to corrosion and accelerated wear.

Similarly, fire resistant fluids have a natural water which may be different to mineral oil.

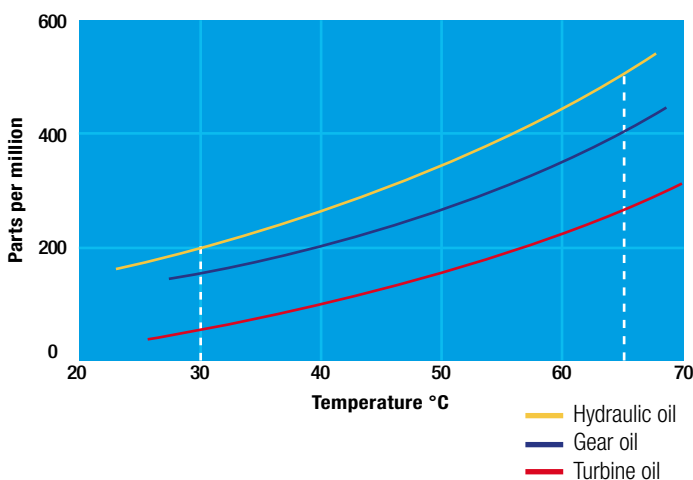

Saturation Levels

Since the effects of free (also emulsified) water is more harmful than those of dissolved water, water levels should remain well below the saturation point.

However, even water in solution can cause damage and therefore every reasonable effort should be made to keep saturation levels as low as possible. There is no such thing as too little water. As a guideline, we recommend maintaining saturation levels below 50% in all equipment.

TYPICAL WATER SATURATION LEVEL FOR NEW OILS

Examples:

Hydraulic oil @ 30°C = 200 ppm = 100% saturation

Hydraulic oil @ 65°C = 500 ppm = 100% saturation

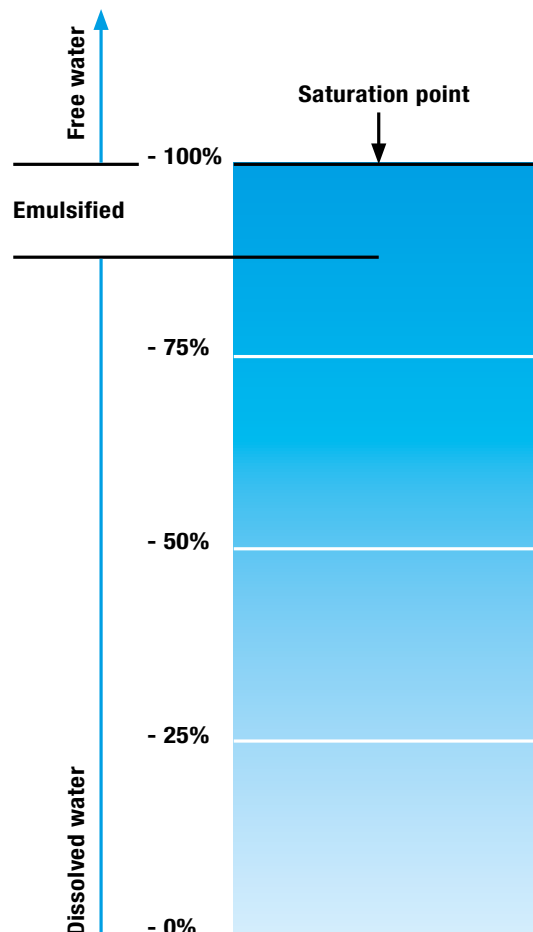

WATER REMOVAL

Water is present everywhere, during storage, handling and servicing.

MP Filtri filter elements feature an absorbent media which protects hydraulic systems from both particulate and water contamination.

MP Filtri's filter element technology is available with inorganic microfiber media with a filtration rating 25 µm (therefore identified with media designation WA025), providing absolute filtration of solid particles to $\beta_{x(c)} = 1000$.

Absorbent media is made by water absorbent fibres which increase in size during the absorption process.

Free water is thus bonded to the filter media and completely removed from the system (it cannot even be squeezed out).

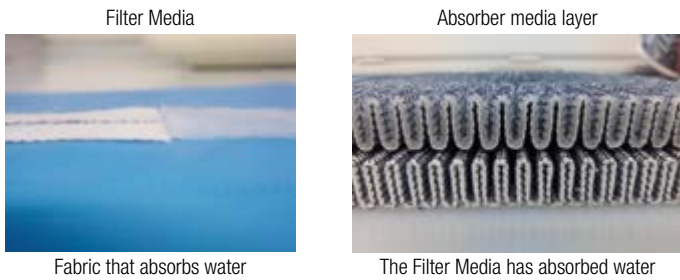

Fabric that absorbs water

The Filter Media has absorbed water

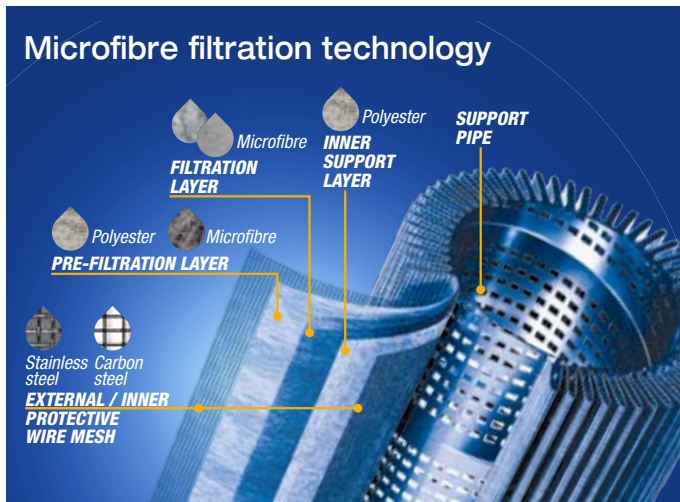

By removing water from your fluid power system, you can prevent such key problems as:

- corrosion (metal etching)
- loss of lubricant power
- accelerated abrasive wear in hydraulic components
- valve-locking
- bearing fatigue
- viscosity variance (reduction in lubricating properties)
- additive precipitation and oil oxidation
- increase in acidity level
- increased electrical conductivity (loss of dielectric strength)
- slow/weak response of control systems



Scan or click me!

For more details please refer to our dedicate brochure "WATER REMOVAL"

12 THE ANTI-STATIC FILTERS



zerospark is a specialist solution designed to solve the problem of electrostatic discharge inside hydraulic filters. Caused by the electrical charge build-up due to the passage of oil through the filters, this can result in damage to filter elements, oils and circuit components. It can even cause fire hazards in environments where flammable materials are present.

THE TRIBOELECTRIC EFFECT

The body with the most electronegativity strips electrons from the other, generating a build-up of a net negative charge on itself. The other body is charged by the same amount but with the opposite sign, giving rise to very high potential differences. These, if not dissipated, can give rise to electrostatic discharges.

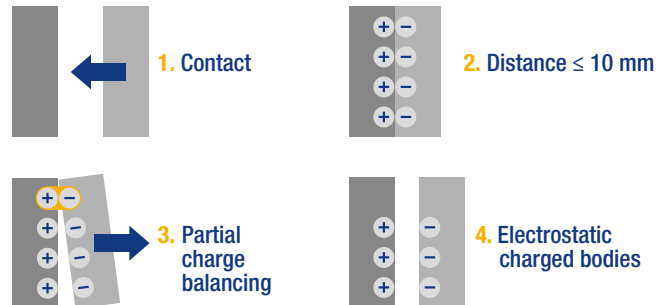

Scan or click me!

For more details please refer to our dedicate brochure "ZEROSPARK"

Filters sizing software

The web-based software program will allow you to select the most suitable MP Filtri's Filters, in accordance with your process design requirements.

The program will automatically check your input design process prior to propose you the acceptable solutions and create an output in PDF report style format.

The MP Filtri Selection Tool software program is easy to use with a flexible fast design method and provides improved layout formats with full descriptions.

The web-based tool is available at MP Filtri website at following link: <https://www.mpfiltri.com/tools/>

The related, complete user guide is available as Manual and downloadable from the "Download" section of MP Filtri website, as well as scanning the following QR code



Scan or click me!



ATEX FILTER

STAINLESS STEEL FILTER

RETURN FILTER

RETURN / SUCTION FILTER

DUPLEX FILTER
LOW & MEDIUM PRESSURE

HIGH PRESSURE FILTER

SUCTION FILTERS

LOW & MEDIUM PRESSURE FILTER

DUPLEX FILTER
HIGH PRESSURE

DUPLEX HIGH CAPACITY INDUSTRIAL FILTERS

SIMPLEX HIGH CAPACITY INDUSTRIAL FILTERS

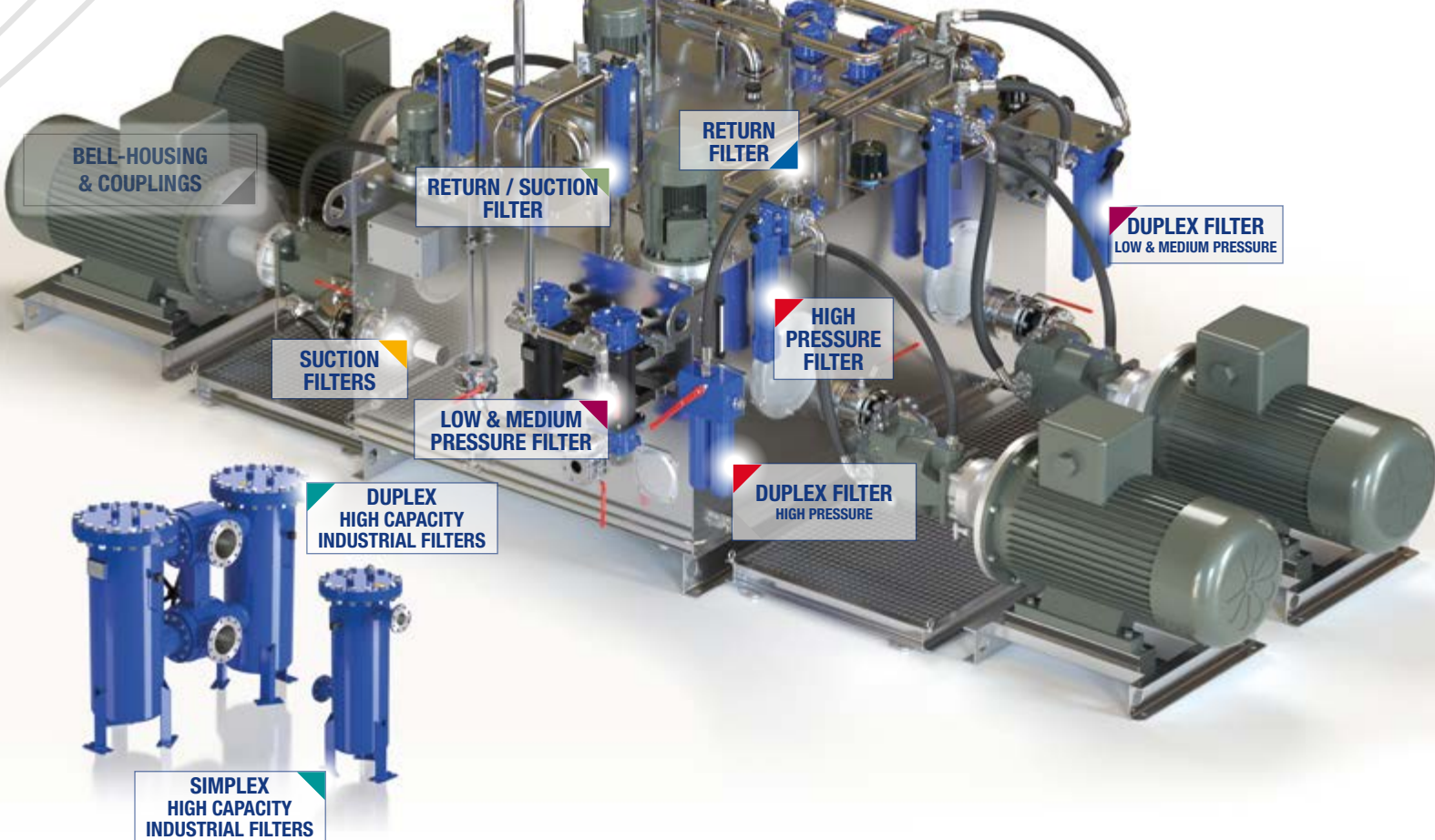

Hydraulic combined filters for installation on the return and suction lines of hydrostatic transmissions (HSTs) for commercial vehicles, construction machinery, agricultural vehicles, and mobile work equipment with hydrostatic drive.

Advantage for the installation:

- **Space-saving assembly**
- **Reduced assembly time**
- **Fewer connections to the tank**
- **Protection from the pollution of the tank**

Advantages for the operativity:

- **Absolute filtration of the oil for the hydrostatic drive**
- **Fulfilment of the purity requirements according to ISO 4406, as specified by the manufacturer of the driving drives.**
- **Protection against damages from cavitation even under adverse conditions, i.e. cold start**
- **Less formation of free air in the system**
- **Easier maintenance operations (one spare filter element instead of two)**

FILTER SIZING

For the proper calculation see pag. 22

Return / Suction filters



Filter sizing and corrective Factors	page 274
MRSX	277
LMP 124 MULTIPOST	291
INDICATORS	778

FILTER SIZING Calculation

THE CORRECT FILTER SIZING HAS TO BE BASED ON THE TOTAL PRESSURE DROP DEPENDING ON THE APPLICATION.

The pressure drop calculation is performed by adding together the value of the housing with the value of the filter element. The pressure drop Δp_c of the housing is proportional to the fluid density (kg/dm^3 / lb/ft^3).

The filter element pressure drop Δp_e is proportional to its viscosity (mm^2/s / SUS), the corrective factor Y have to be used in case of an oil viscosity different than $30 \text{ mm}^2/\text{s}$ (cSt) / 150 SUS.

Sizing data for single filter element, head at top

Δp_c = Filter housing pressure drop [bar / psi]

Δp_e = Filter element pressure drop [bar / psi]

Y = Corrective factor Y (see correspondent table), depending on the filter type, on the filter element size, on the filter element length and on the filter media

Q = flow rate (l/min - gpm)

V1 reference oil viscosity = $30 \text{ mm}^2/\text{s}$ (cSt) / 150 SUS

V2 = operating oil viscosity in mm^2/s (cSt) / SUS

Filter element pressure drop calculation with an oil viscosity different than $30 \text{ mm}^2/\text{s}$ (cSt) / 150 SUS

International system:

$$\Delta p_e = Y : 1000 \times Q \times (V2:V1)$$

Imperial system:

$$\Delta p_e = Y : 17.2 \times Q \times (V2:V1)$$

$$\Delta p_{\text{Tot.}} = \Delta p_c + \Delta p_e$$

Verification formula

$$\Delta p_{\text{Tot.}} \leq \Delta p_{\text{max allowed}}$$

Maximum total pressure drop (Δp_{max}) allowed by a new and clean filter

Filter family	Δp_{max}	
	[bar]	[psi]
Return - Suction filters (*)	1.50 bar	22 psi

(*)The suction flow rate should not exceed 30% of the return flow rate

Filter pressure drop calculation example

Application data:

Selected filter: **MRSX 166 length 3**

Selected filter element: **RSX 165 length 3**

Selected filtration rating: **25 μm** absolute filtration with microfibre

Flow rate Q = **180 l/min / 47,55 gpm**

Viscosity V2 = $46 \text{ mm}^2/\text{s}$ (cSt) / 216 SUS

Oil density = $0.86 \text{ kg}/\text{dm}^3$ / $53.68 \text{ lb}/\text{ft}^3$

Calculation:

$$\Delta p_c = \mathbf{0.65 \text{ bar} / 9.42 \text{ psi}}$$
 (see graphic below)

MRSX 165/166

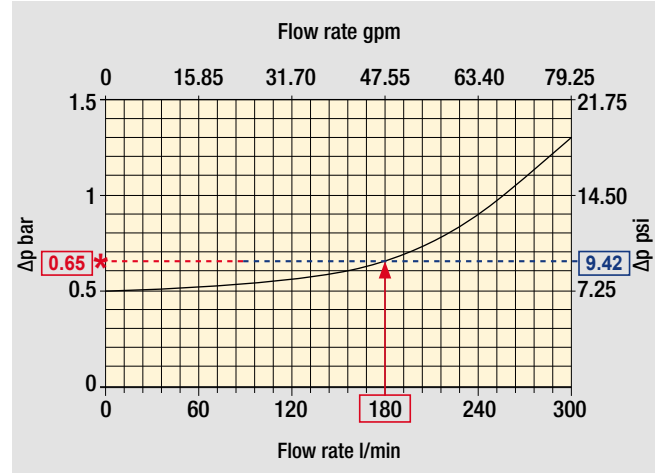

Filter housings Δp pressure drop.

The curves are plotted using mineral oil with density of $0.86 \text{ kg}/\text{dm}^3$ in compliance with ISO 3968. Δp varies proportionally with density.

Filter element		Absolute filtration Filter Elem. Δp Series: D		
Type	Length	A10	A16	A25
RSX 165	1	2.06	1.75	1.46
	2	1.24	1.05	0.96
	3	0.94	0.86	0.61

$$\Delta p_e = (0.61 : 1000) \times 180 \times (46 : 30) = 0.17 \text{ bar}$$

$$\Delta p_e = (0.61 : 17.2) \times 47.55 \times (216 : 150) = 2.43 \text{ psi}$$

$$\checkmark \Delta p_{\text{Tot.}} = 0.65 + 0.17 = 0.82 \text{ bar}$$

$$\checkmark \Delta p_{\text{Tot.}} = 9.42 + 2.43 = 11.85 \text{ psi}$$

The selection is correct because the total pressure drop value is inside the admissible range for return/suction filters.

In case the max allowed total pressure drop is not verified, it is necessary to repeat the calculation changing the filter and/or filter element length/size.

Corrective factors RETURN / SUCTION FILTERS

Filter element		Absolute filtration		
Type	Length	A10	A16	A25
RSX 116	1	5.12	4.33	3.85
	2	2.22	1.87	1.22
RSX 165	1	2.06	1.75	1.46
	2	1.24	1.05	0.96
	3	0.94	0.86	0.61

Filter element		Absolute filtration Filter Element ΔP Series: N							
Type	Length	A03	A06	A10	A16	A25	P10	P25	M25 - M60 - M90
CU 110	1	16.25	15.16	8.75	8.14	5.87	2.86	2.65	0.14
	2	12.62	10.44	6.11	6.02	4.16	1.60	1.49	0.12
	3	8.57	7.95	5.07	4.07	2.40	1.24	1.15	0.11
	4	5.76	4.05	4.05	2.36	1.14	0.91	0.85	0.05

Corrective factor Y to be used for the filter element pressure drop calculation. The values depend to the filter size and length and to the filter media.
Reference oil viscosity 30 mm²/s



THE X CONCEPT FOR OUR FILTERS

Protect the performance of your system with MYclean.
Quality and efficiency are fundamental for MP Filtri:
this exclusive new filter element possesses polygon shape geometry and specific seal
that ensures only original spare parts can be used - ensuring correct operation and
higher system reliability.

MRSX series

with MY CLEAN RSX Filter Element



- ◆ **Protects the machine from improper use of non-original products.**
- ◆ **Safety of constant quality protection & reliability**

With exclusive filter element you are sure that only MP Filtri filter elements can be used, ensuring the best cleaning level of the oil due to the use of originals filter elements.



The products identified as MRSX are protected by:

- ◆ Italian Patent n° 102014902261205
- ◆ Canadian Patent n° 2,937,258
- ◆ European Patent n° 3 124 092 B1
- ◆ US Patent n° 20170030384 A1

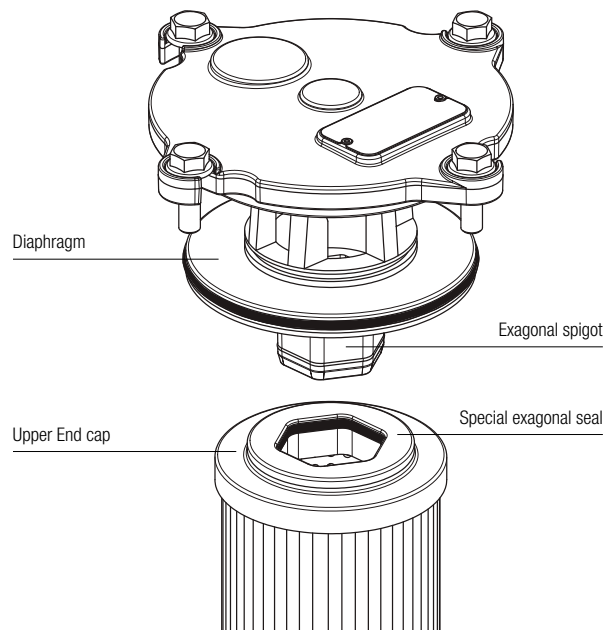
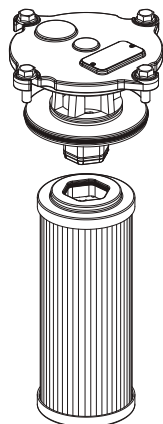
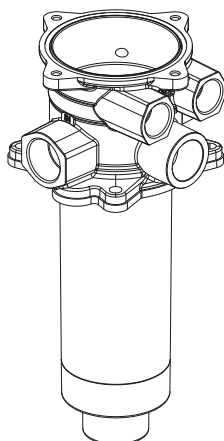

MRSX series

Maximum working pressure up to 1 MPa (10 bar) - Flow rate up to 250 l/min



Description

Technical data

Return / Suction filter

Tank mounted

Maximum working pressure up to 1 MPa (10 bar)
Flow rate up to 250 l/min

MRSX is a range of suction/return filters for hydraulic systems with two or more circuits (both open and closed loops). They are able to provide pressurized oil cleaned by fine filtration to the feed pump of the hydrostatic systems.

They are directly fixed to the reservoir, in immersed or semi-immersed position.

The filter output must be always immersed into the fluid to avoid aeration or foam generation into the reservoir.

Available features:

- Female threaded return connections up to 1 1/4", for a maximum return flow rate of 250 l/min
- Multiple connections, to connect several return and suction lines
- Fine filtration rating, to get a good cleanliness level into the reservoir
- Bypass valve to the tank, to relieve excessive pressure drop across the filter media when the return flow is enough higher than the suction flow
- Bypass valve to the suction line with additional suction filter element, to relieve excessive pressure drop across the filter media when the return flow is not enough higher than the suction flow
- De-pressurization valve, to reduce the pressure inside the filter during the maintenance operations
- Anti-cavitation valve with additional suction filter element, to ensure fluid to the feed pump of the hydrostatic systems during cold starts or initial filling
- O-ring or Flat Seal to suit a variety of reservoir surfaces
- Reservoir side mounting, to save space in the machines
- Visual, electrical and electronic clogging indicators
- MYclean interface connection, to protect the product against non-original spare parts
- External protective wrap, to optimize the flow through the element and to save the element efficiency against non-proper handling

Common applications:

Mobile machines with hydrostatic systems on board
 (i.e. skid steer loaders, telehandlers, dumpers, road sweepers)

Filter housing materials

- Head: Aluminium
- Cover
 Polyamide: MRSX 116
 Aluminium: MRSX 165-166
- Bowl: Polyamide

Pressure

- Test pressure: 1.5 MPa (15 bar)
- Min. Burst pressure: 3 MPa (30 bar)
- Pulse pressure fatigue test: 1 000 000 cycles with pressure from 0 to 1 MPa (10 bar)

Filter element features

Filter MRSX		Filter element RSX
Δp Element type		
Element media	Construction	Δp
A - Microfiber	Standard	10 bar
<i>Please see ordering code tables to check element Δp series availability based on filter features.</i>		
Flow direction through the filter element:		
From OUT to IN		

Seals

- Standard NBR series A
- Optional FPM series V

Temperature

From -25 °C to +110 °C

Flow rates [l/min]

Filter series	Length	A10	A16	A25
MRSX 116	1	74	82	87
	2	108	113	124
MRSX 165 - 166	1	155	166	178
	2	187	196	200
	3	201	205	217

Maximum flow rate for a complete return/suction filter with a pressure drop Δp = 1 bar.

The reference fluid has a kinematic viscosity of 30 mm²/s (cSt) and a density of 0.86 kg/dm³.

For different pressure drop or fluid viscosity we recommend to use our selection software available on www.mpfiltr.com.

You can also calculate the right size using the formulas present on the FILTER SIZING paragraph at the beginning of the full catalogue or at the beginning of the filter family brochure. Please, contact our Sales Department for further additional information.

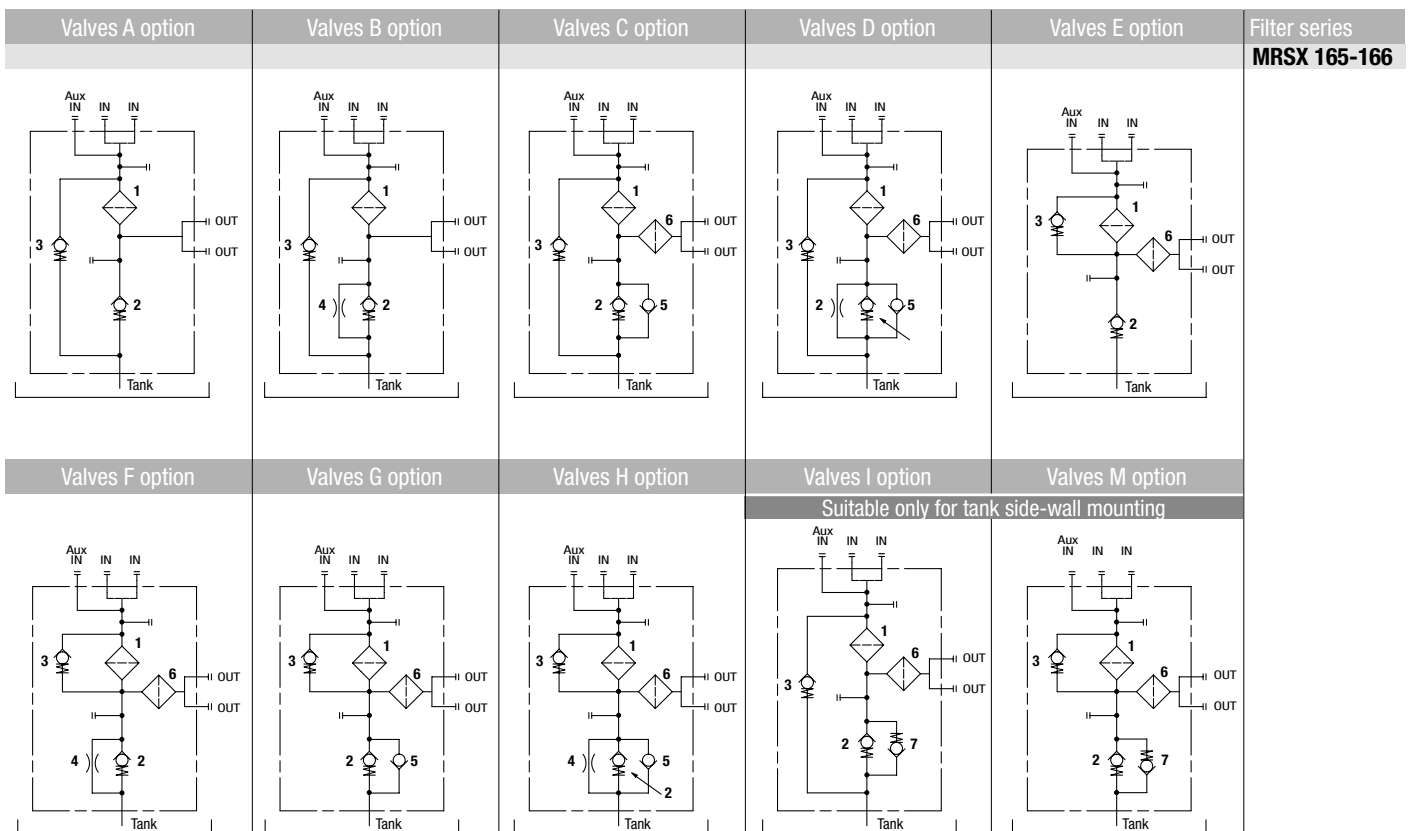
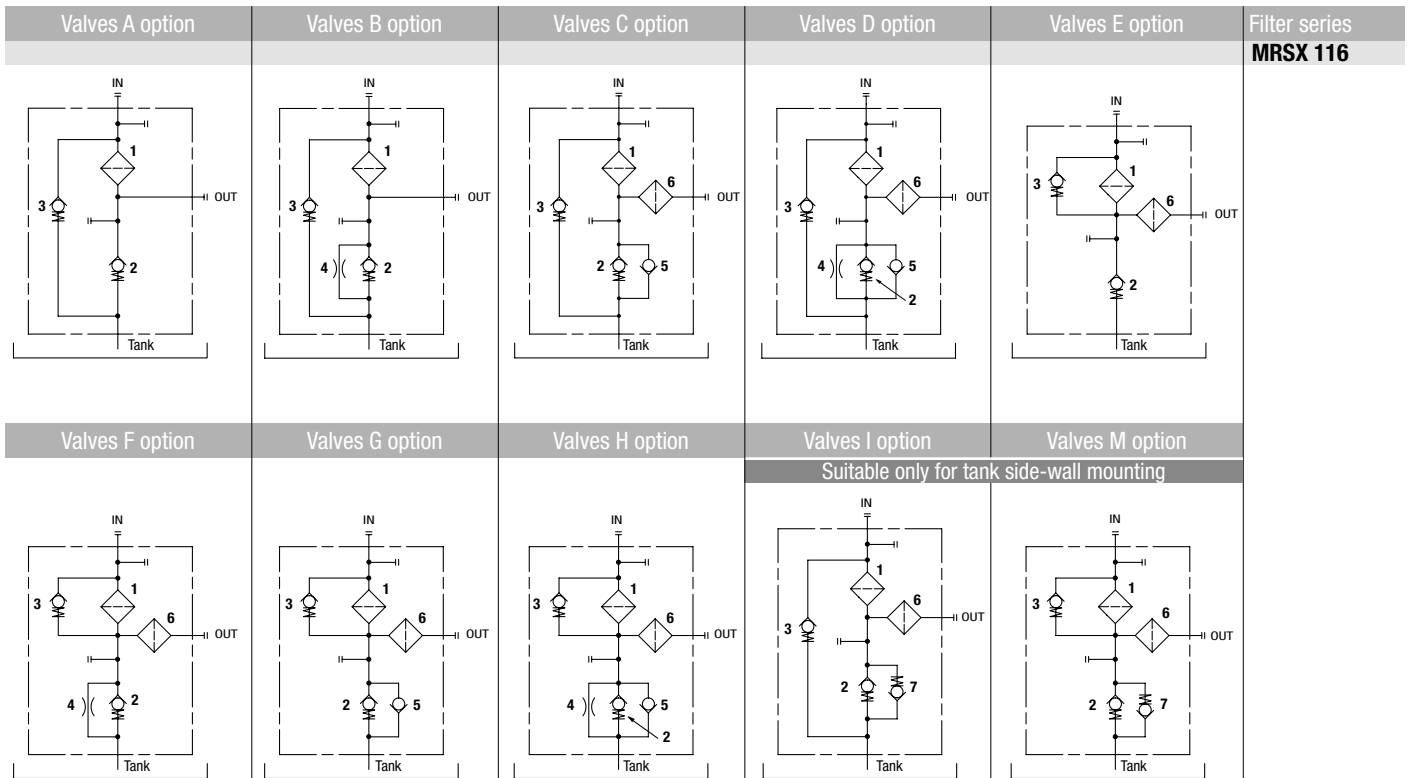

LEGEND

- 1 - Filter element
- 2 - Back-Pressure valve: opening pressure 0.5 bar \pm 10%
- 3 - Bypass valve: opening pressure 2.5 bar \pm 10%
- 4 - Depressurization valve

- 5 - Anti-Cavitation valve
- 6 - Safety filter element (wire mesh 60 μ m)
- 7 - Anti-Cavitation valve / Anti-Emptying valve

MRSX GENERAL INFORMATION

Pressure drop

Filter housings Δp pressure drop

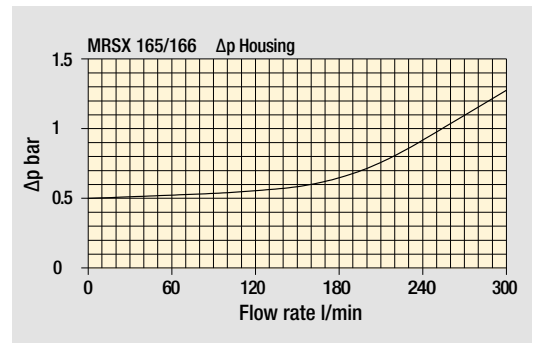
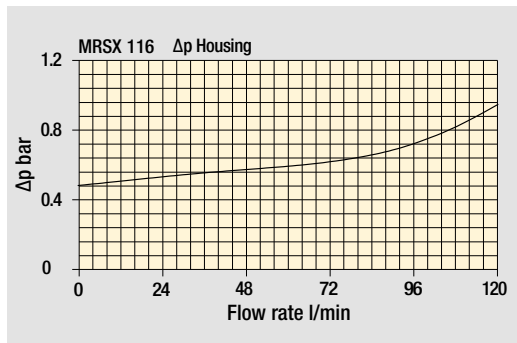

Bypass valve pressure drop

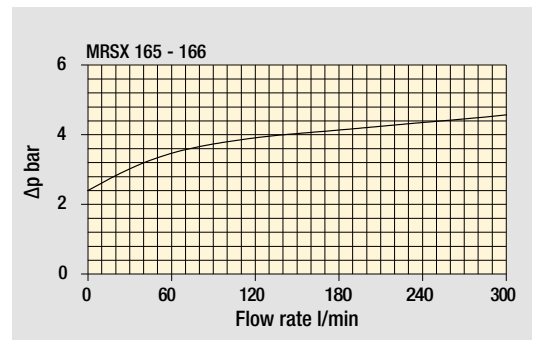
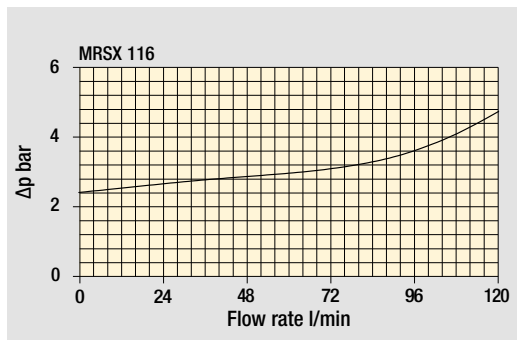

The curves are plotted using mineral oil with density of 0.86 kg/dm³ in compliance with ISO 3968. Δp varies proportionally with density.

Weights [kg] and volumes [dm³]

Filter series	Weights [kg]			Volumes [dm ³]				
	Length	1	2	3	Length	1	2	3
MRSX 116		1.30	1.40	-		0.80	1.00	-
MRSX 165		3.40	3.80	4.10		2.00	2.60	3.00
MRSX 166		3.40	3.80	4.10		2.00	2.60	3.00

Designation & Ordering code

COMPLETE FILTER

Series and size Configuration example: **MRSX116** | **1** | **B** | **A** | **G1** | **0** | **A16** | **B** | **P01**

MRSX116 Filter featuring **MY CLEAN** Filter Element

Length
1 | **2**

Hydraulic diagram configuration - see page 275

				Bypass valve to tank		Bypass valve to OUT	
A	B	C	D	•	-	-	-
E	F	G	H	-	-	•	-
I				•	-	-	-
M				-	-	•	-

Seals and treatments

A NBR, O-Ring on head	B NBR, flat seal on head
V FPM, O-Ring on head	D FPM, flat seal on head

Connections IN

Connections IN	Connections OUT
G1 G 3/4"	G 3/4"
G2 G 1"	G 1"
G3 3/4" NPT	3/4" NPT
G4 1" NPT	1" NPT
G5 SAE 12 - 1 1/16" - 12 UN	SAE 12 - 1 1/16" - 12 UN
G6 SAE 16 - 1 5/16" - 12 UN	SAE 16 - 1 5/16" - 12 UN
D1 G 1"	G 3/4"
D2 1" NPT	3/4" NPT
D3 SAE 16 - 1 5/16" - 12 UN	SAE 12 - 1 1/16" - 12 UN

Aux IN connection

0 Without aux IN connection

Filtration rating (filter media)

A10 Inorganic microfiber	10 µm
A16 Inorganic microfiber	16 µm
A25 Inorganic microfiber	25 µm

Valves configuration

Mounting position	A	B	C	D	E	F	G	H	I	M
S Standard	•	•	•	•	•	•	•	•	-	-
B Tank side-wall mounting	•	•	-	-	•	•	-	-	•	•

Execution

P01 MP Filtri standard
Pxx Customized

FILTER ELEMENT

Element series and size

RSX116 Filter Element with **MY CLEAN** feature

Configuration example: **RSX116** | **1** | **A16** | **A** | **P01**

Element length

1 | **2**

Filtration rating (filter media)

A10 Inorganic microfiber	10 µm
A16 Inorganic microfiber	16 µm
A25 Inorganic microfiber	25 µm

Seals

A NBR
V FPM

Execution

P01 MP Filtri standard
Pxx Customized

CLOGGING INDICATORS

See pages 778-780

Indicators on Return Line

BVA Axial pressure gauge
BVR Radial pressure gauge
BVP Visual pressure indicator with automatic reset
BVQ Visual pressure indicator with manual reset

BEA Electrical pressure indicator
BEM Electrical pressure indicator
BET Electrical pressure indicator
BLA Electrical / visual pressure indicator

Indicators on Suction Line

VVB Axial vacuum gauge
VVS Radial vacuum gauge

VEB Electrical vacuum indicator
VLB Electrical / visual vacuum indicator

MRSX116		
Filter length	H1 [mm]	H2 [mm]
1	203	240
2	263	300

Connections	T
G1 - G2	G 1/8"
G3 - G4	1/8" NPT
G5 - G6	1/8" NPT
D1	G 1/8"
D2 - D3	1/8" NPT

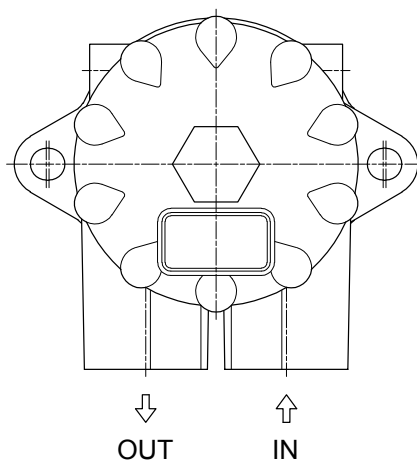
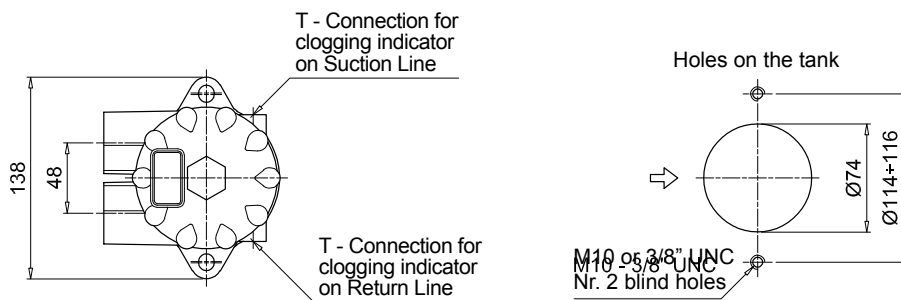
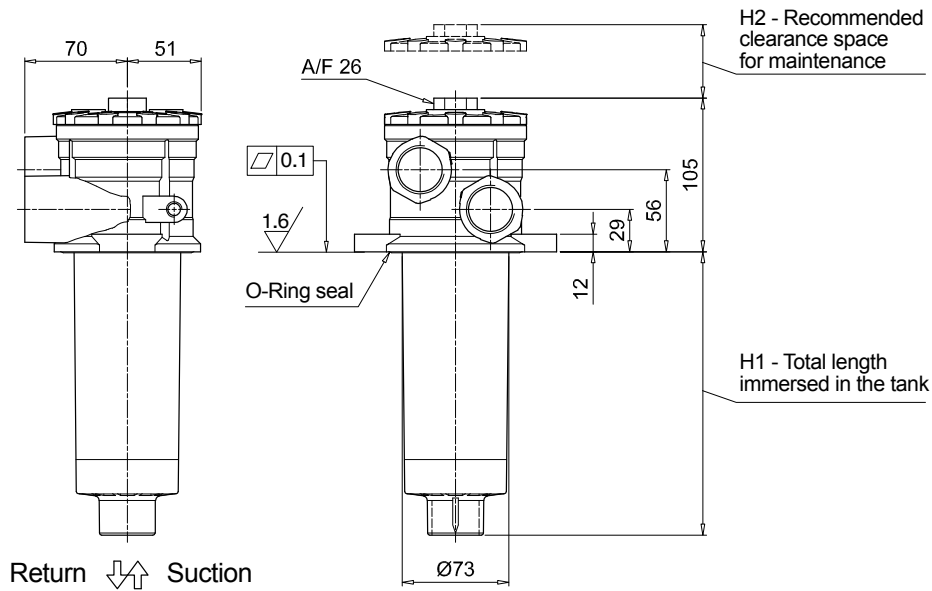

MRSX MRSX165 - MRSX166

Designation & Ordering code

COMPLETE FILTER

Series and size Configuration example: **MRSX166** | **2** | **C** | **V** | **G3** | **1** | **A10** | **S** | **P01**

MRSX165 | **MRSX166** Filter featuring **MYCLEAN** Filter Element

Length **1** | **2** | **3**

Hydraulic diagram configuration - see page 275

A	B	C	D	Bypass valve to tank	Bypass valve to OUT
				•	-
E	F	G	H	-	•
I				•	-
M				-	•

Seals and treatments

A	B
NBR, O-Ring on head	NBR, flat seal on head
FPM, O-Ring on head	FPM, flat seal on head

Connections

	IN (size 165)	IN (size 166)	Aux IN	OUT
G1	G 1 1/4"	G 1"	G 1 1/4"	G 1"
G2	1 1/4" NPT	1" NPT	1 1/4" NPT	1" NPT
G3	SAE 20 - 1 5/8" - 12 UN	SAE 16 - 1 5/16" - 12 UN	SAE 20 - 1 5/8" - 12 UN	SAE 16 - 1 5/16" - 12 UN

Aux IN connection

	MRSX 165	MRSX 166
0 Without aux IN connection	•	-
1 With aux IN connection - see previous table	•	•

Filtration rating (filter media)

A10	Inorganic microfiber	10 µm
A16	Inorganic microfiber	16 µm
A25	Inorganic microfiber	25 µm

Valves configuration

Mounting position	A	B	C	D	E	F	G	H	I	M
S Standard	•	•	•	•	•	•	•	•	-	-
B Tank side-wall mounting	•	•	-	-	•	•	-	-	•	•

Execution

P01	MP Filtri standard
Pxx	Customized

FILTER ELEMENT

Element series and size Configuration example: **RSX165** | **2** | **A10** | **V** | **P01**

RSX165 Filter Element with **MYCLEAN** feature

Element length **1** | **2** | **3**

Filtration rating (filter media)

A10	Inorganic microfiber	10 µm
A16	Inorganic microfiber	16 µm
A25	Inorganic microfiber	25 µm

Seals

A	V
NBR	FPM

Execution

P01	MP Filtri standard
Pxx	Customized

CLOGGING INDICATORS

See pages 778-780

Indicators on Return Line

BVA	Axial pressure gauge
BVR	Radial pressure gauge
BVP	Visual pressure indicator with automatic reset
BVQ	Visual pressure indicator with manual reset

BEA	Electrical pressure indicator
BEM	Electrical pressure indicator
BET	Electrical pressure indicator
BLA	Electrical / visual pressure indicator

Indicators on Suction Line

VVB	Axial vacuum gauge
VVS	Radial vacuum gauge

VEB	Electrical vacuum indicator
VLB	Electrical / visual vacuum indicator

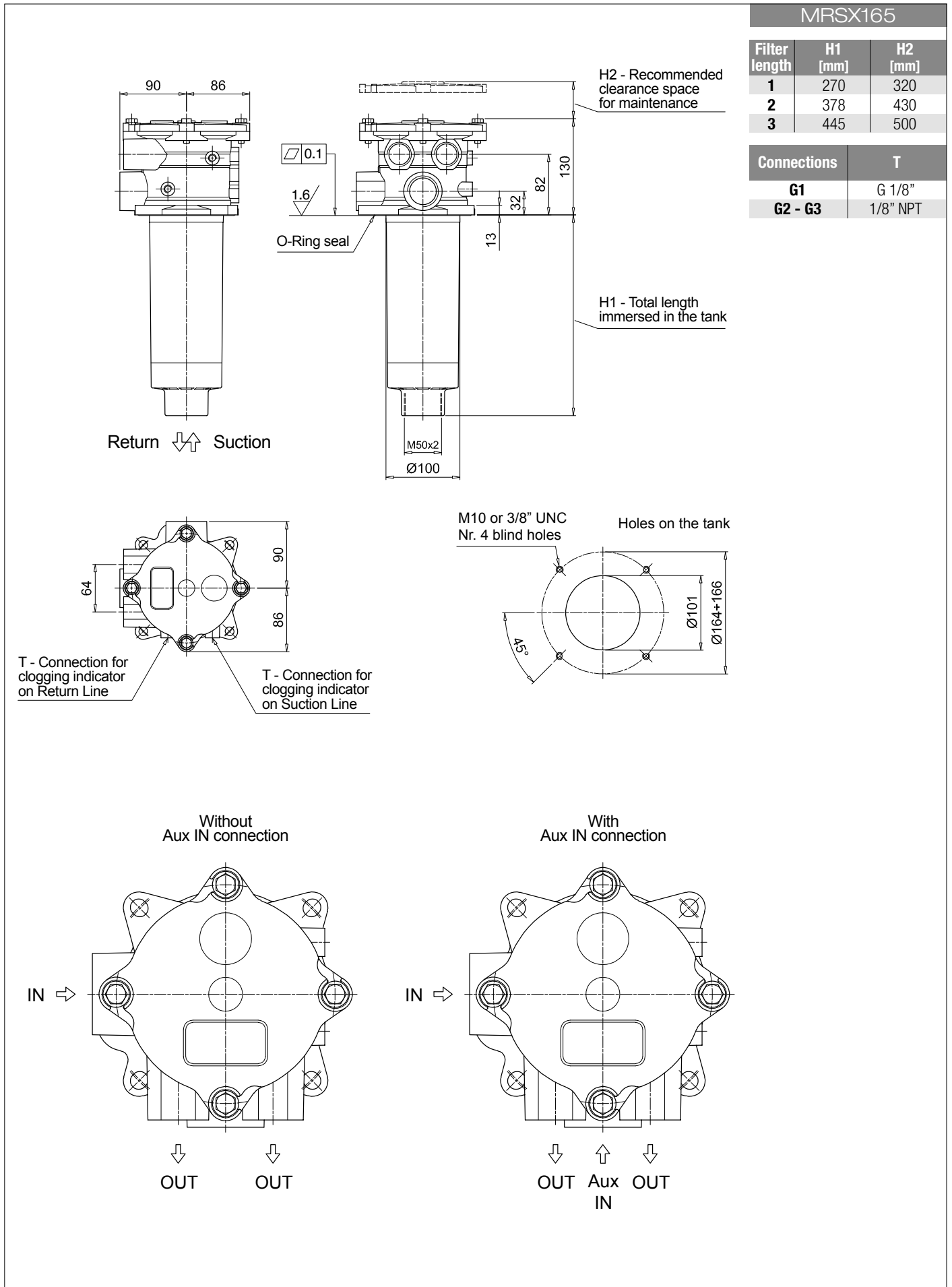

MRSX MRSX165 - MRSX166

Dimensions

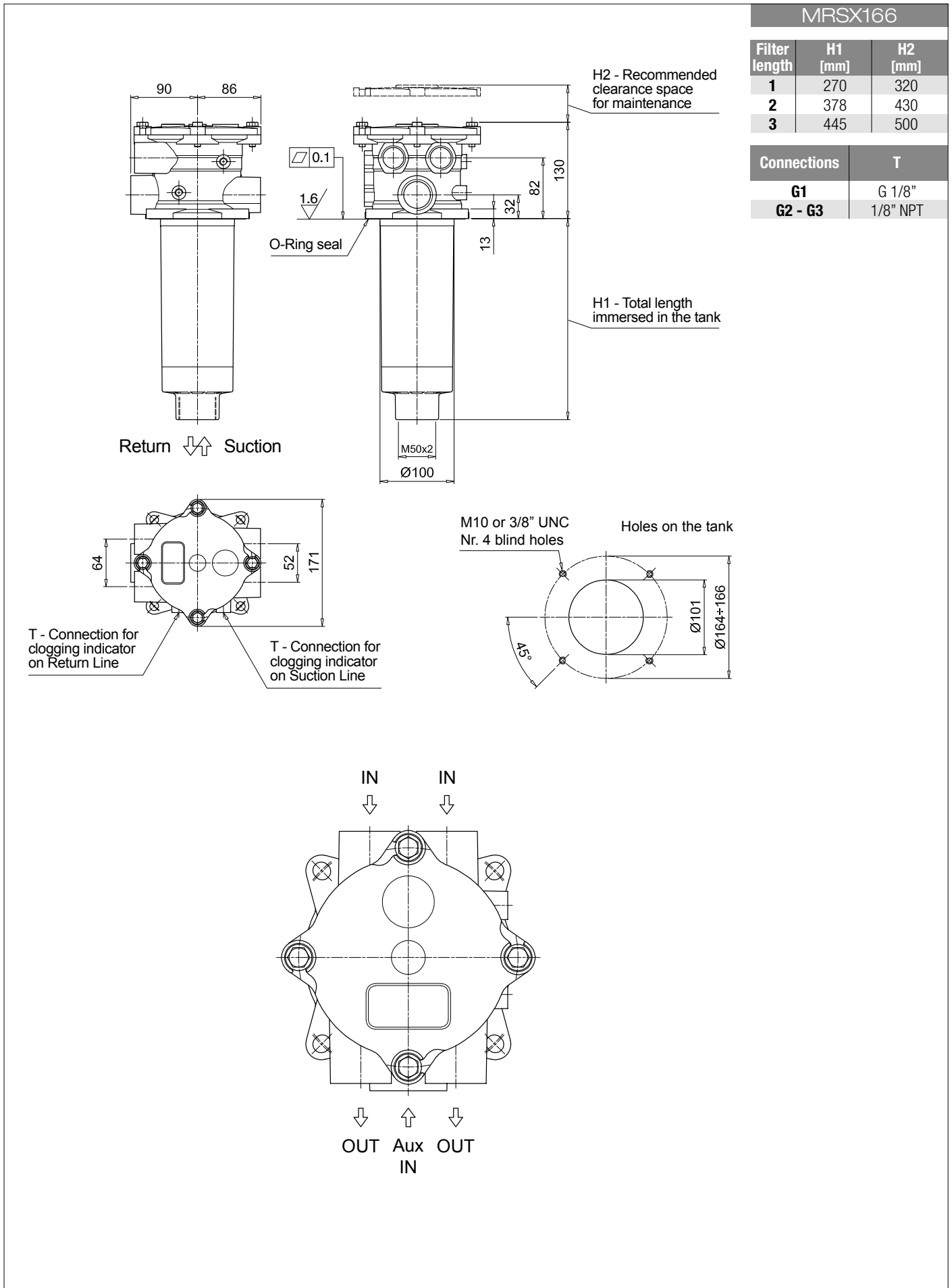

MRSX SPARE PARTS

Order number for spare parts

MRSX 116

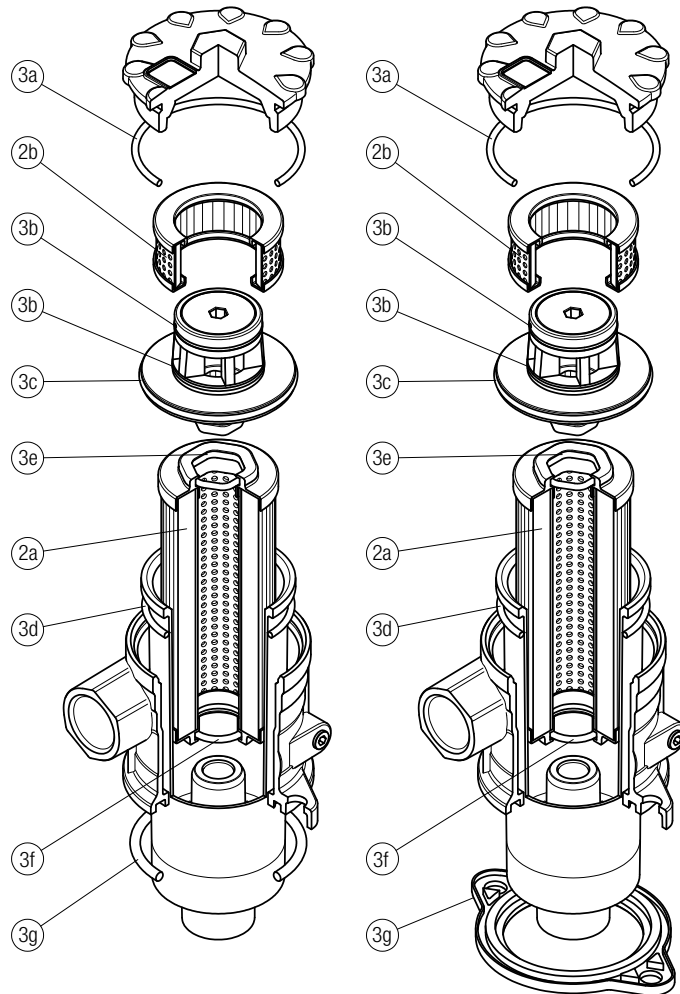

Item:	Q.ty: 1 pc.	Q.ty: 1 pc.	O-RING SEAL Q.ty: 1 pc.		FLAT SEAL Q.ty: 1 pc.	
	2a	2b	3 (3a ÷ 3g)		3 (3a ÷ 3g)	
Filter series	Filter element	Safety filter element	Seal Kit code number		Seal Kit code number	
			NBR	FPM	NBR	FPM
MRSX 116	See order table	S116M60P01	02050617	02050619	02050618	02050620

MRSX 165 - 166

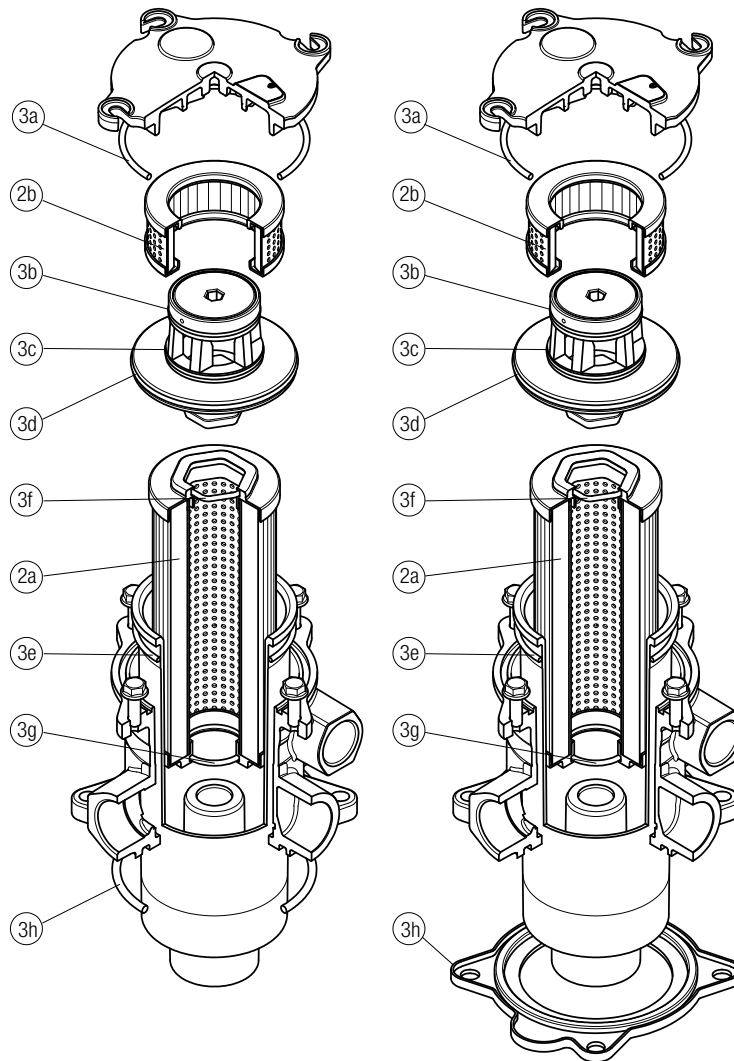

Item:	Q.ty: 1 pc.	Q.ty: 1 pc.	O-RING SEAL		FLAT SEAL	
	2a	2b	Q.ty: 1 pc.		Q.ty: 1 pc.	
Filter series	Filter element	Safety filter element	3 (3a ÷ 3h)		3 (3a ÷ 3h)	
			Seal Kit code number NBR	Seal Kit code number FPM	Seal Kit code number NBR	Seal Kit code number FPM
MRSX 165	See order table	S165M60P01	02050627	02050630	02050628	02050631
MRSX 166			02050627	02050630	02050629	02050632

LMP 124 series

MULTI-PORT

Maximum working pressure up to 8 MPa (80 bar) - Flow rate up to 120 l/min



Description

Technical data

Return / Suction filter

In-line

Maximum working pressure up to 8 MPa (80 bar)
Flow rate up to 120 l/min

LMP124 is a range of return/suction filters for hydraulic systems with two or more circuits (both open and closed loops). They are able to provide pressurized oil cleaned by fine filtration to the feed pump of the hydrostatic systems.

They are directly connected to the lines of the system through the hydraulic fittings.

Available features:

- Female threaded connections up to 1", for a maximum return flow rate of 120 l/min
- Fine filtration rating, to get a good cleanliness level into the reservoir
- Bypass valve to the tank, to relieve excessive pressure drop across the filter media when the return flow is enough higher than the suction flow
- Bypass valve to the suction line with additional suction filter element, to relieve excessive pressure drop across the filter media when the return flow is not enough higher than the suction flow
- De-pressurization valve, to reduce the pressure inside the filter during the maintenance operations
- Visual, electrical and electronic differential clogging indicators

Common applications:

Mobile machines with hydrostatic systems on board.
 (i.e. skid steer loaders, telehandlers, dumpers, road sweepers)

Filter housing materials

- Head: Aluminium
- Housing: Cathaphoresis - Painted steel
- Bypass valve: Brass - Aluminium

Pressure

- Test pressure: 12 MPa (120 bar)
- Min. Burst pressure: 24 MPa (240 bar)
- Pulse pressure fatigue test: 1 000 000 cycles with pressure from 0 to 8 MPa (80 bar)

Bypass valve

- Opening pressure 0.25 MPa (2.5 bar) ±10%
- Other opening pressures on request.

Filter element features

Filter LMP 124		Filter element CU	
Δp Element type			
Element media	Construction	Δp Series	Δp
A - Microfiber	Standard	N	20 bar
M - Wire mesh	Standard	N	20 bar
P - Paper	Standard	N	20 bar
<i>Please see ordering code tables to check element Δp series availability based on filter features.</i>			
Flow direction through the filter element:			
From OUT to IN			

Seals

- Standard NBR series A
- Optional FPM series V

Temperature

From -25 °C to +110 °C

Note

LMP124 filters are provided for vertical mounting

Weights [kg] and volumes [dm³]

Filter series	Weights [kg]					Volumes [dm ³]				
	Length	1	2	3	4	Length	1	2	3	4
LMP 124		1.70	1.90	2.20	2.70		0.75	0.81	1.11	1.53

Flow rates [l/min]

Filter series	Length	Filter element design - N series							
		A03	A06	A10	A16	A25	M25 M60 M90	P10	P25
LMP 124	1	39	41	58	60	69	99	84	85
	2	47	53	68	69	77	99	90	91
	3	59	61	73	77	86	99	92	93
	4	70	78	84	86	93	100	94	95

Maximum flow rate for a complete return/suction filter with a pressure drop $\Delta p = 1.2$ bar.

The reference fluid has a kinematic viscosity of 30 mm²/s (cSt) and a density of 0.86 kg/dm³.

For different pressure drop or fluid viscosity we recommend to use our selection software available on www.mpfiltri.com.

You can also calculate the right size using the formulas present on the FILTER SIZING paragraph at the beginning of the full catalogue or at the beginning of the filter family brochure. Please, contact our Sales Department for further additional information.

Hydraulic diagram - Valves option

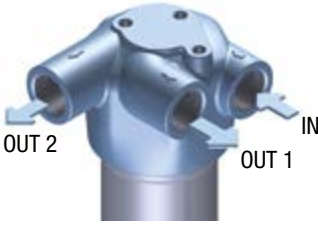
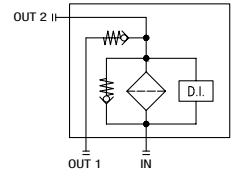
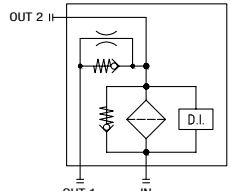
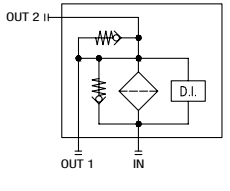
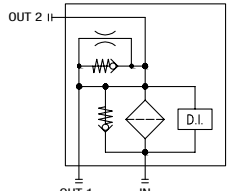
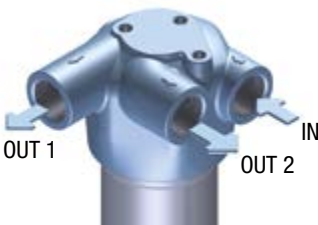
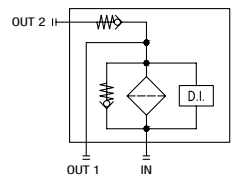
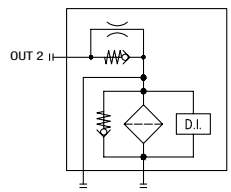
Multiport	Valves C option	Valves D option	Valves E option	Valves F option
 <p>IN - Return OUT 1 - Tank OUT 2 - Pump</p>				
Multiport	Valves G option	Valves H option		
 <p>IN - Return OUT 1 - Pump OUT 2 - Tank</p>				

Filter housings Δp pressure drop

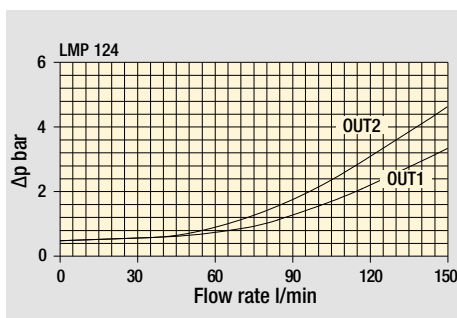

OUT 1: Valves option G/H
OUT 2: Valves option C/D/E/F

Bypass valve pressure drop

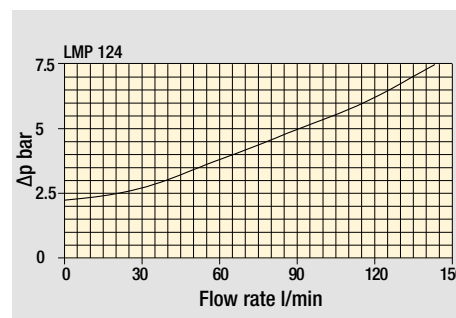

Pressure drop

Designation & Ordering code

COMPLETE FILTER

Configuration example: **LMP124** **4** **C** **A** **F** **1** **A10** **N** **P01**

Series and size
LMP124

Filter length
1 | **2** | **3** | **4**

Hydraulic diagram configuration - see page 293
C | **D** | **E** | **F** | **G** | **H**

Seals and treatments
A NBR
V FPM

Connections
B G 1"
F SAE 16 - 1 5/16" - 12 UN

Connection for indicator
1 Without
2 With connection G 1/8" for clogging indicator
3 With connection G 1/4" for clogging indicator
4 With connection for differential pressure indicator

Filtration rating (filter media)

A03	Inorganic microfiber	3 µm
A06	Inorganic microfiber	6 µm
A10	Inorganic microfiber	10 µm
A16	Inorganic microfiber	16 µm
A25	Inorganic microfiber	25 µm
M25	Wire mesh	25 µm
M60	Wire mesh	60 µm
M90	Wire mesh	90 µm
P10	Resin impregnated paper	10 µm
P25	Resin impregnated paper	25 µm

Element Δp
N 20 bar

Execution
P01 MP Filtri standard
Pxx Customized

CLOGGING INDICATORS

See pages 282-285

Indicators on Return Line

BVA	Axial pressure gauge
BVR	Radial pressure gauge
BVP	Visual pressure indicator with automatic reset
BVQ	Visual pressure indicator with manual reset

BEA	Electrical pressure indicator
BEM	Electrical pressure indicator
BET	Electrical pressure indicator
BLA	Electrical / visual pressure indicator

Differential pressure indicators

DEA	Electrical differential pressure indicator
DEM	Electrical differential pressure indicator
DEU	Electrical differential pressure indicator
DLA	Electrical / visual differential pressure indicator
DLE	Electrical / visual differential pressure indicator

DTA	Electronic differential pressure indicator
DTI	I-O Link electronic differential pressure indicator
DVA	Visual differential pressure indicator
DVM	Visual differential pressure indicator

PLUGS

See page 807

T2	Plug (not included)
-----------	---------------------

FILTER ELEMENT

Element series and size CU110	Configuration example:	CU110	4	A10	A	N	P01
Element length 1 2 3 4							
Filtration rating (filter media)							
A03 Inorganic microfiber	3 µm						
A06 Inorganic microfiber	6 µm						
A10 Inorganic microfiber	10 µm						
A16 Inorganic microfiber	16 µm						
A25 Inorganic microfiber	25 µm						
M25 Wire mesh	25 µm						
M60 Wire mesh	60 µm						
M90 Wire mesh	90 µm						
P10 Resin impregnated paper	10 µm						
P25 Resin impregnated paper	25 µm						
Seals and treatments							
A NBR							
V FPM							
		Element Δp		Execution			
		N 20 bar		P01 MP Filtri standard			
				Pxx Customized			

Dimensions

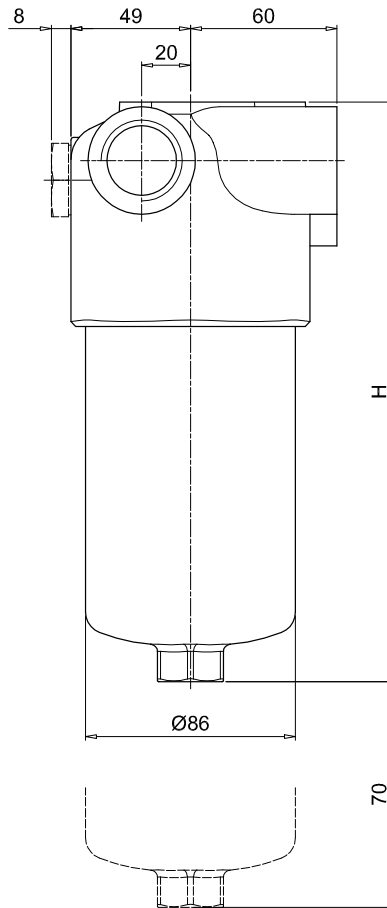
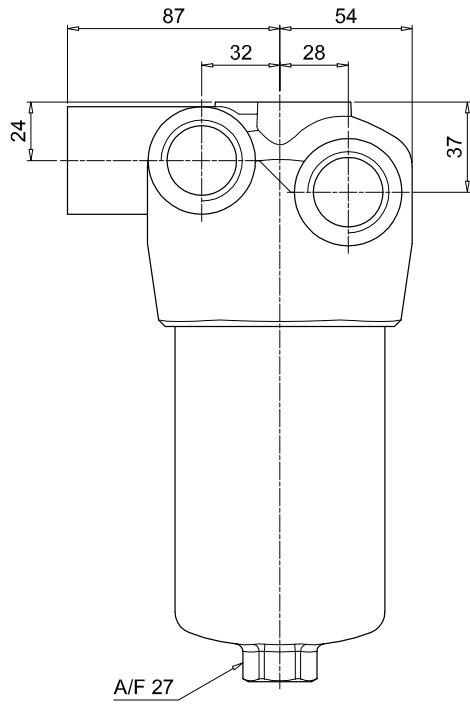

LMP 124	
MULTIPORT	
Filter length	H [mm]
1	197
2	230
3	280
4	380
Connections	G
B	M10
F	3/8" UNC

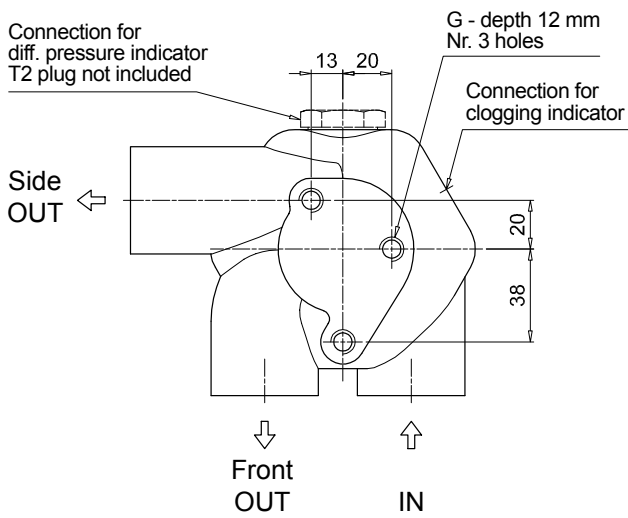

Recommended clearance space for maintenance

LMP 124 MULTIPOINT

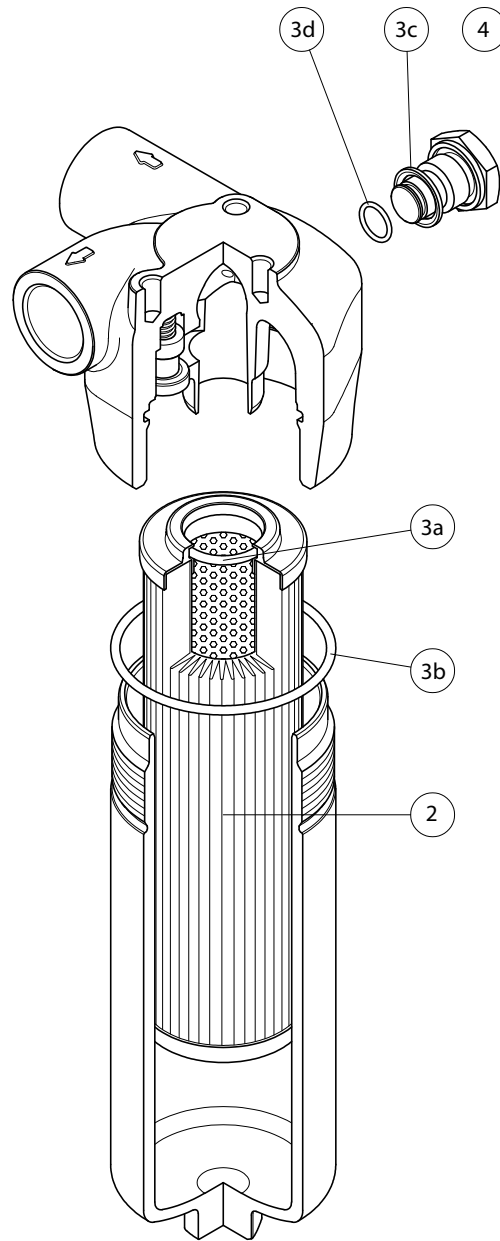

Item:	Q.ty: 1 pc.	Q.ty: 1 pc.		Q.ty: 1 pc.	
Filter series	Filter element	Seal Kit code number		Indicator connection plug	
LMP 124 MULTIPOINT	See order table	NBR	FPM	NBR	FPM
	2	3 (3a ÷ 3d)		4	
		02050478	02050479	T2H	T2V

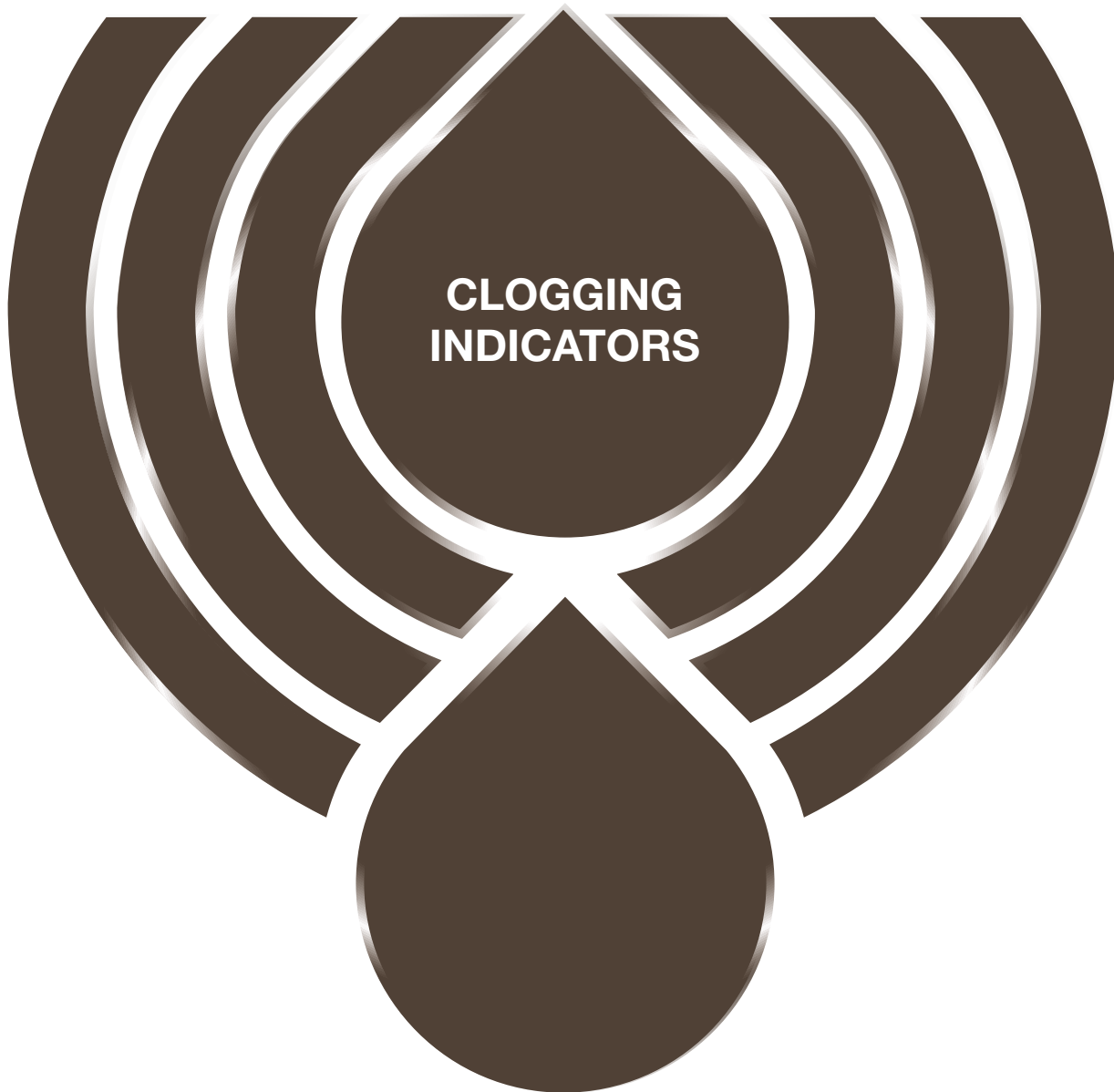

Clogging indicators are devices that check the life time of the filter elements. They measure the pressure drop through the filter element directly connected to the filter housing.

These devices trip when the clogging of the filter element causes a pressure drop increasing across the filter element.

Filter elements are efficient only if their Dirt Holding Capacity is fully exploited. This is achieved by using filter housings equipped with clogging indicators.

The indicator is set to alarm before the element becomes fully clogged.

MP Filtri can supply indicators of the following designs:

- Vacuum switches and gauges
- Pressure switches and gauges
- Differential pressure indicators

These type of devices can be provided with a visual, electrical or both signals. The electronic differential pressure clogging indicator is also available. It provides both analogical 4-20 mA output and digital warning (75% of clogging) and alarm (clogging) outputs.

In the following pages you can find a reference guide about the types of clogging indicators available in the different families of MP Filtri's Hydraulic Filtration range of products.

Clogging Indicators



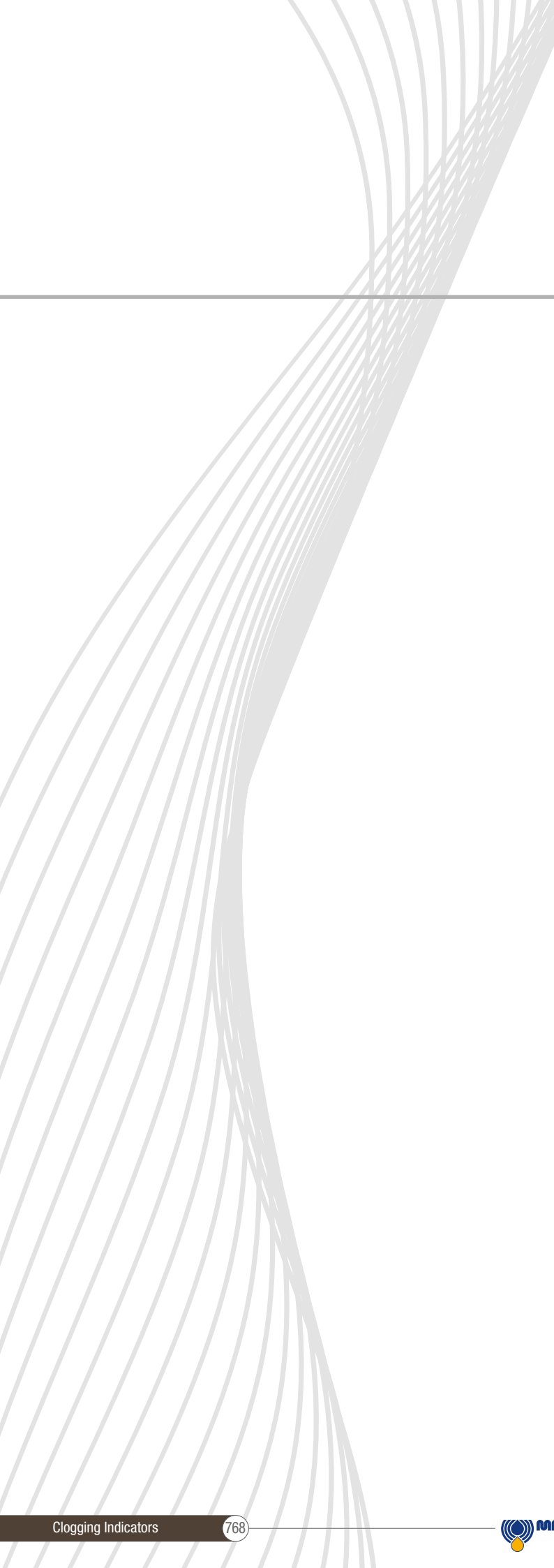

DESIGNATION, ORDERING CODES & TECHNICAL DATA

INDEX

	Page
QUICK REFERENCE GUIDE	770
CLOGGING INDICATORS ORDERING CODES	
SUCTION FILTERS INDICATORS	775
RETURN FILTERS INDICATORS	776
RETURN / SUCTION FILTERS INDICATORS	778
SPIN-ON FILTERS INDICATORS	781
LOW & MEDIUM PRESSURE FILTERS INDICATORS	784
HIGH CAPACITY INDUSTRIAL FILTERS INDICATORS	785
HIGH PRESSURE FILTERS INDICATORS	786
STAINLESS STEEL HIGH PRESSURE FILTERS INDICATORS	787
FILTERS FOR POTENTIALLY EXPLOSIVE ATMOSPHERE INDICATORS	788
TECHNICAL DATA	
VACUUM INDICATORS	790
BAROMETRIC (PRESSURE) INDICATORS	792
DIFFERENTIAL PRESSURE INDICATORS	796
PLUGS	807

QUICK REFERENCE GUIDE

Ordering codes

Filter family	Filter series	Visual indicators	Electrical indicators	Electronic / Electrical-Visual indicators
SUCTION FILTERS	ELIXIR® SFEX 060-110	VVB20P01 VVS20P01	VEB21AA50P01	VLB21AA51P01 VLB21AA52P01 VLB21AA53P01 VLB21AA71P01
	Suction Line SFM250	VVA20P01 VVR20P01	VEA21xA50P01 VEA21xA50P01UL	VLA21xA51P01 VLA21xA52P01 VLA21xA53P01 VLA21xA71P01
	Without bypass SFSC 500 - 503 - 504 - 505 SFSC 510 - 535 - 540	VVA20P01 VVR20P01	VEA21xA50P01 VEA21xA50P01UL	VLA21xA51P01 VLA21xA52P01 VLA21xA53P01 VLA21xA71P01
RETURN FILTERS	With bypass 1.75 bar ELIXIR® RFEX 060-110	BVA14P01 BVR14P01 BVP15HP01 BVQ15HP01	BEA15HA50P01 BEA15HA50P01UL BEM15HA41P01	BLA15HA51P01 BLA15HA52P01 BLA15HA53P01 BLA15HA71P01
	Without bypass ELIXIR® RFEX 060-110	BVA25P01 BVR25P01 BVP20HP01 BVQ20HP01	BEA20HA50P01 BEA20HA50P01UL BEM20HA41P01	BLA20HA51P01 BLA20HA52P01 BLA20HA53P01 BLA20HA71P01
	With bypass 1.75 bar MDHC 250	BVA14P01 BVR14P01 BVP15HP01 BVQ15HP01 DVS12HP01	BEA15HA50P01 BEA15HA50P01UL BEM15HA41P01 DES12HA10P01 DES12HA30P01 DES12HA80P01	BLA15HA51P01 BLA15HA52P01 BLA15HA53P01 BLA15HA71P01
	With bypass 3 bar MDHC 250	BVA25P01 BVR25P01 BVP20HP01 BVQ20HP01 DVS25HP01	BEA20HA50P01 BEA20HA50P01UL BEM20HA41P01 BET20HF10P01 BET20HF30P01 BET25HF10P01 BET25HF30P01 DES25HA10P01 DES25HA30P01 DES25HA80P01	BLA20HA51P01 BLA20HA52P01 BLA20HA53P01 BLA20HA71P01
	With bypass 1.75 bar MPFX MPTX MPHC	BVA14P01 BVR14P01 BVP15HP01 BVQ15HP01	BEA15HA50P01 BEA15HA50P01UL BEM15HA41P01	BLA15HA51P01 BLA15HA52P01 BLA15HA53P01 BLA15HA71P01
	With bypass 3 bar MPFX MPTX	BVA25P01 BVR25P01 BVP20HP01 BVQ20HP01	BEA20HA50P01 BEA20HA50P01UL BEM20HA41P01 BET20HF10P01 BET20HF30P01	BLA20HA51P01 BLA20HA52P01 BLA20HA53P01 BLA20HA71P01
	With bypass 2.5 bar MPHC	BVA25P01 BVR25P01 BVP20HP01 BVQ20HP01	BEA20HA50P01 BEA20HA50P01UL BEM20HA41P01 BET20HF10P01 BET20HF30P01	BLA20HA51P01 BLA20HA52P01 BLA20HA53P01 BLA20HA71P01
	With bypass 4.5 bar MPLX	DVA20xP01 DVM20xP01	DEA20xA50P01 DEM20xx10P01 DEM20xx20P01 DEM20xx30P01 DEM20xx35P01	DLA20xA51P01 DLA20xA52P01 DLA20xA71P01 DLE20xA50P01 DLE20xF50P01
	Return line FRIC 025 - 040 - 100 - 250 - 630 - 850		DEU20VA50P01UL	DTA20xF70P01 DTI20xA70P01
	Return line FRIC 255	BVA25P01 BVR25P01 BVP20HP01 BVQ20HP01	BEA20HA50P01 BEA20HA50P01UL BEM20HA41P01	BLA20HA51P01 BLA20HA52P01 BLA20HA53P01 BLA20HA71P01

Filter family	Filter series	Visual indicators	Electrical indicators	Electronic / Electrical-Visual indicators	
RETURN / SUCTION FILTERS	MRSX 116 - 165 - 166 Suction line	VVB20P01 VVS20P01	VEB21AA50P01	VLB21AA51P01 VLB21AA52P01 VLB21AA53P01 VLB21AA71P01	
	With bypass 2.5 bar		BEA20HA50P01 BEA20HA50P01UL		
	MRSX 116 - 165 - 166 Return line	BVA25P01 BVR25P01 BVP20HP01 BVQ20HP01	BEM20HA41P01 BET25HF10P01 BET25HF30P01 BET25HF50P01	BLA20HA51P01 BLA20HA52P01 BLA20HA53P01 BLA20HA71P01	
With bypass 2.5 bar	LMP 124 MULTIPORT		BEA20HA50P01 BEA20HA50P01UL	BLA20HA51P01 BLA20HA52P01 BLA20HA53P01 BLA20HA71P01	
		BVA25P01 BVR25P01 BVP20HP01 BVQ20HP01	BEM20HA41P01	DLA20xA51P01 DLA20xA52P01 DLA20xA71P01 DLE20xA50P01 DLE20xF50P01	
		DVA20xP01 DVM20xP01	DEA20xA50P01 DEM20xx10P01 DEM20xx20P01 DEM20xx30P01 DEM20xx35P01 DEU20VA50P01UL	DTA20xF70P01 DTI20xA70P01	
SPIN-ON FILTERS	Suction line	MPS 050 - 070 - 100 - 150 MPS 200 - 250 - 300 - 350	VWB20P01 VWS20P01	VEB21AA50P01	VLB21AA51P01 VLB21AA52P01 VLB21AA53P01 VLB21AA71P01
	Return line	MPS 050 - 070 - 100 - 150 MPS 200 - 250 - 300 - 350	BVA14P01 BVR14P01 BVP15HP01 BVQ15HP01	BEA15HA50P01 BEA15HA50P01UL BEM15HA41P01	BLA15HA51P01 BLA15HA52P01 BLA15HA53P01 BLA15HA71P01
	In-line	MPS 051 - 071 - 101 - 151 MPS 301 - 351	DVA12xP01 DVM12xP01 DVA20xP01 DVM20xP01	DEA12xA50P01 DEM12xAxxP01 DEA20xA50P01 DEM20xAxxP01 DEU20VA50P01UL	DLA12xA51P01 DLA12xA52P01 DLA12xA71P01 DLA20xA51P01 DLA20xA52P01 DLA20xA71P01 DLE12xA50P01 DLE12xF50P01 DLE20xF50P01 DLE20xF50P01 DTA12xF70P01 DTA20xF70P01 DTI12xA70P01 DTI20xA70P01

QUICK REFERENCE GUIDE

Ordering codes

Filter family	Filter series	Visual indicators	Electrical indicators	Electronic / Electrical-Visual indicators		
LOW & MEDIUM PRESSURE FILTERS	ELIXIR® HFEX 060-110	DVS25HP01	DES25HA50P01			
	ELIXIR® LFEX 060-080-110-160	DVS25HP01	DES25HA10P01 DES25HA30P01 DES25HA50P01 DES25HA80P01			
	With bypass 3.5 bar	LMP 110 LMP 112 - 116 - 118 - 119 MULTIPORT LMP 120 - 122 - 123 MULTIPORT LMP 210 - 211 - LDP LMP 400 - 401 & 430 - 431 LMP 900 - 901 LMP 902 - 903 LMP 950 - 951 LMP 952 - 953 - 954 LMD 211 - 400 - 401 - 431 - 951 - LDD	DVA20xP01 DVM20xP01	DEA20xA50P01 DEM20xx10P01 DEM20xx20P01 DEM20xx30P01 DEM20xx35P01 DEU20VA50P01UL	DLA20xA51P01 DLA20xA52P01 DLA20xA71P01 DLE20xA50P01 DLE20xF50P01 DTA20xF70P01 DTI20xA70P01	
	With bypass 2.5 bar	LPH 630	DVA20xP01 DVM20xP01	DEA20xA50P01 DEM20xx10P01 DEM20xx20P01 DEM20xx30P01 DEM20xx35P01 DEU20VA50P01UL	DLA20xA51P01 DLA20xA52P01 DLA20xA71P01 DLE20xA50P01 DLE20xF50P01 DTA20xF70P01 DTI20xA70P01	
	With bypass 1.75 bar	LPH 630	DVA12xP01 DVM12xP01	DEA12xA50P01 DEM12xx10P01 DEM12xx20P01 DEM12xx30P01 DEM12xx35P01	DLA12xA51P01 DLA12xA52P01 DLA12xA71P01 DLE12xA50P01 DLE12xF50P01 DTA12xF70P01 DTI12xA70P01	
	HIGH CAPACITY INDUSTRIAL FILTERS	ELIXIR® HFEX 060-110	DVS40HP01	DES40HA50P01		
		ELIXIR® LFEX 060-080-110-160	DVS40HP01	DES40HA10P01 DES40HA30P01 DES40HA50P01 DES40HA80P01		
		Without bypass	LMP 110 LMP 112 - 116 - 118 - 119 MULTIPORT LMP 120 - 122 - 123 MULTIPORT LMP 210 - 211 - LDP LMP 400 - 401 & 430 - 431 LMP 900 - 901 LMP 902 - 903 LMP 950 - 951 LMP 952 - 953 - 954 LMD 211 - 400 - 401 - 431 - 951 - LDD LPH 630	DVA50xP01 DVM50xP01	DEA50xA50P01 DEM50xx10P01 DEM50xx20P01 DEM50xx30P01 DEM50xx35P01 DEU50VA50P01UL	DLA50xA51P01 DLA50xA52P01 DLA50xA71P01 DLE50xA50P01 DLE50xF50P01 DTA50xF70P01 DTI50xA70P01
		With bypass 3.5 bar	MLPX MLDX	DVA20xP01 DVM20xP01	DEA20xA50P01 DEM20xx10P01 DEM20xx20P01 DEM20xx30P01 DEM20xx35P01v	DLA20xA51P01 DLA20xA52P01 DLA20xA71P01 DLE20xA50P01 DLE20xF50P01 DTA20xF70P01 DTI20xA70P01
		With bypass 1.75 bar	MLPC MLDC	DVA12xP01 DVM12xP01	DEA12xA50P01 DEM12xx10P01 DEM12xx20P01 DEM12xx30P01 DEM12xx35P01	DLA12xA51P01 DLA12xA52P01 DLA12xA71P01 DLE12xA50P01 DLE12xF50P01 DTA12xF70P01 DTI12xA70P01
		Without bypass	MLDC MLPC	DVA50xP01 DVM50xP01	DEA50xA50P01 DEM50xx10P01 DEM50xx20P01 DEM50xx30P01 DEM50xx35P01	DLA50xA51P01 DLA50xA52P01 DLA50xA71P01 DLE50xA50P01 DLE50xF50P01 DTA50xF70P01 DTI50xA70P01

Filter family	Filter series	Visual indicators	Electrical indicators	Electronic / Electrical-Visual indicators				
HIGH PRESSURE FILTERS	With bypass 6 bar	FMP 039 - 065 - 135 - 320 FHP 010 - 011 - 065 - 135 - 350 - 351 - 500 FMMX 050 - 150 FMM 050 - 150 FHA 051 FHM 006 - 007 - 010 - 050 - 065 - 135 - 320 - 500 FHB 050 - 135 - 320 FHF 325 FHD 021 - 051 - 326 - 333	DVA50xP01 DVM50xP01	DEA50xA50P01 DEM50xx10P01 DEM50xx20P01 DEM50xx30P01 DEM50xx35P01 DEU50VA50P01UL	DLA50xA51P01 DLA50xA52P01 DLA50xA71P01 DLE50xA50P01 DLE50xF50P01			
		Without bypass	FMP 039 - 065 - 135 - 320 FHP 010 - 011 - 065 - 135 - 350 - 351 - 500 FMMX 050 - 150 FMM 050 - 150 FHA 051 FHM 006 - 007 - 010 - 050 - 065 - 135 - 320 - 500 FHB 050 - 135 - 320 FHF 325 FHD 021 - 051 - 326 - 333	DVA70xP01 DVA95xP01 DVM70xP01 DVM95xP01	DEA70xA50P01 DEA95xA50P01 DEM70xx10P01 DEM70xx20P01 DEM70xx30P01 DEM70xx35P01 DEU70VA50P01UL DEM95xx10P01 DEM95xx20P01 DEM95xx30P01 DEM95xx35P01	DLA70xA51P01 DLA70xA52P01 DLA70xA71P01 DLA95xA51P01 DLA95xA52P01 DLA95xA71P01 DLE70xA50P01 DLE70xF50P01 DLE95xA50P01 DLE95xF50P01 DTA70xF70P01 DTA95xF70P01 DTI70xA70P01 DTI95xA70P01		
			With bypass 6 bar	FZH 012 - 040	DVZ50xP01	DEZ50xA50P01	DLZ50xA51P01 DLZ50xA52P01	
				Without bypass	FZH 012 - 040	DVZ70xP01 DVZ95xP01	DEZ70xA50P01 DEZ95xA50P01	DLZ70xA51P01 DLZ70xA52P01 DLZ95xA51P01 DLZ95xA52P01
					Without bypass	FZP 039 - 136 FZB 039 FZM 039 FZD 051	DVX50xP01 DYY50xP01	DEX50xA50P01
				Without bypass		FZP 039 - 136 FZB 039 FZM 039 FZD 010 - 021 - 051	DVX70xP01 DVX95xP01 DYY70xP01 DYY95xP01	DEX70xA50P01 DEX95xA50P01
			FILTERS FOR POTENTIALLY EXPLOSIVE ATMOSPHERE		With bypass 6 bar	FMMX 050 - 150	DVA50xP01 DVM50xP01	DEH50xA48P01 DEH50xA49P01 DEH50xA70P01
				Without bypass		FMMX 050 - 150	DVA70xP01 DVA95xP01 DVM70xP01 DVM95xP01	DEH70xA48P01 DEH70xA49P01 DEH70xA70P01
					With bypass 6 bar	FZP 039 - 136	DVX50xP01 DYY50xP01	DEH50xA48P01 DEH50xA49P01 DEH50xA70P01
				Without bypass		FZP 039 - 136	DVX70xP01 DVX95xP01 DYY70xP01 DYY95xP01	DEH70xA48P01 DEH70xA49P01 DEH70xA70P01
With bypass 6 bar	FZH 012 - 040				DVZ50xP01			
	Without bypass	FZH 012 - 040		DVZ70xP01 DVZ95xP01				

Suitable indicator types

V ACUUM INDICATORS

Vacuum indicators are used on the Suction line to check the efficiency of the filter element.

They measure the pressure downstream of the filter element.

Standard items are produced with R 1/4" EN 10226 connection.

Available products with R 1/8" EN 10226 to be fitted on MPS series.

Vacuum indicators are identified in the Hydraulic Filtration catalogue and in the Quick Reference Guide table by the letter "V".

Example:

V VVB20P01

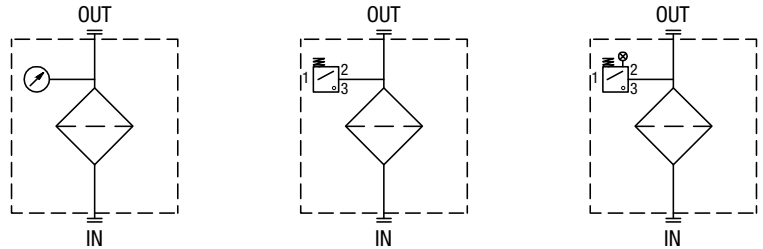

B BAROMETRIC (PRESSURE) INDICATORS

Pressure indicators are used on the Return line to check the efficiency of the filter element.

They measure the pressure upstream of the filter element.

Standard items are produced with R 1/8" EN 10226 connection.

Barometric (pressure) indicators are identified in the Hydraulic Filtration catalogue and in the Quick Reference Guide table by the letter "B".

Example:

B BVA14P01

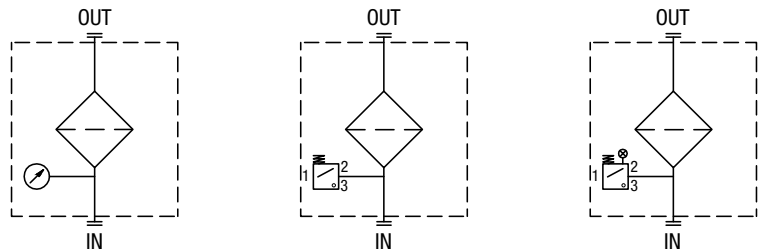

D DIFFERENTIAL PRESSURE INDICATORS

Differential pressure indicators are used on the Pressure line to check the efficiency of the filter element.

They measure the pressure upstream and downstream of the filter element (differential pressure).

Standard items are produced with special connection G 1/2" size.

Also available in Stainless Steel models. Differential pressure indicators are identified in the Hydraulic Filtration catalogue and in the Quick Reference Guide table by the letter "D".

Example:

D DVA20xP01

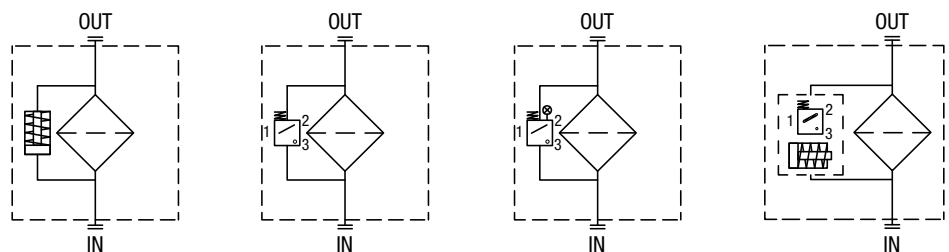

Designation & Ordering code

APPLICABLE VACUUM INDICATORS BY FILTER SERIES

Filter Series	VEB	VLB	VVB	VVS
MRSX	•	•	•	•
LMP124	-	-	-	-

VACUUM INDICATORS

Series	Configuration example 1:	VE	B	21	V	A	50	P01	EX
VE Electrical vacuum indicator	Configuration example 2:	VL	B	21	A	A	71	P01	
VL Electrical/Visual vacuum indicator	Configuration example 3:	VV	S	20				P01	
VV Vacuum gauge									

Type VE - VL	Type VV
B Connection EN 10226 - R1/8"	B Axial connection EN 10226 - R1/8"
	S Radial connection EN 10226 - R1/8"

Vacuum setting	VE	VL	VVB	VVS
20 0.20 bar	-	-	•	•
21 0.21 bar	•	•	-	-

Seals	VEB - VLB	VV
A NBR	•	-
V FPM	-	-

Thermostat	VE	VL	VV
A Without	•	•	-

Electrical connections	VE	VL
50 Connection EN 175301-803	•	-
51 Connection EN 175301-803, transparent base with lamps 24 Vdc	-	•
52 Connection EN 175301-803, transparent base with lamps 110 Vdc	-	•
53 Connection EN 175301-803, transparent base with lamps 230 Vac	-	•
71 Connection IEC 61076-2-101 D (M12), black base with lamps 24 Vdc	-	•

Option
P01 MP Filtri standard
Pxx Customized

Certifications	VEB	VL	VV
Without	•	•	•
EX ATEX certification	•	-	-

APPLICABLE BAROMETRIC (PRESSURE) INDICATORS BY FILTER SERIES

Filter Series	BEA	BEM	BET	BLA	BVA	BVR	BVP	BVQ
MRSX	•	•	•	•	•	•	•	•
LMP124	•	•	•	•	•	•	•	•

BAROMETRIC (PRESSURE) INDICATORS

Series	Configuration example 1:	BE	M	15	H	A	41	P01	EX
BE Electrical pressure indicator	Configuration example 2:	BL	A	20	H	A	71	P01	
BL Electrical/Visual pressure indicator	Configuration example 3:	BV	R	14				P01	
BV Visual pressure indicator	Configuration example 4:	BV	P	20	H			P01	

Type	BE	BL	BV
A Standard type	•	•	A Axial connection pressure gauge
M With wired electrical connection	•	-	R Radial connection pressure gauge
T With thermal switch	•	-	P Visual indicator with automatic reset
			Q Visual indicator with manual reset

Pressure setting	BEA-BEM	BET	BLA	BVA-BVR	BVP-BVQ
14 1.4 bar	-	-	-	•	-
15 1.5 bar	•	-	•	-	•
20 2.0 bar	•	•	•	-	•
25 2.5 bar	-	•	-	•	-

Seals	BE	BLA	BVA-BVR	BVP-BVQ
H HNBR	•	•	-	•

Thermostat	BEA-BEM	BET	BLA	BV
A Without thermostat	•	-	•	-
F With thermostat	-	•	-	-

Electrical connections	BEA	BEM	BET	BL
10 Connection AMP Superseal series 1.5	-	-	•	-
30 Connection Deutsch DT-04-2-P	-	-	•	-
41 Connection via four-core cable	-	•	-	-
50 Connection EN 175301-803	•	-	•	-
51 Connection EN 175301-803, transparent base with lamps 24 Vdc	-	-	-	•
52 Connection EN 175301-803, transparent base with lamps 110 Vdc	-	-	-	•
53 Connection EN 175301-803, transparent base with lamps 230 Vac	-	-	-	•
71 Connection IEC 61076-2-101 D (M12), black base with lamps 24 Vdc	-	-	-	•

Option
P01 MP Filtri standard
Pxx Customized

Certifications	BEA	BEM-BET	BL	BV
Without	•	•	•	•
EX ATEX certification	•	-	-	-
UL UL certification	•	-	-	-

Designation & Ordering code

APPLICABLE DIFFERENTIAL PRESSURE INDICATORS BY FILTER SERIES

Filter Series	DEA	DEM	DEU	DLA	DLE	DTA	DTI	DVA	DVM
MRSX	-	-	-	-	-	-	-	-	-
LMP124	•	•	•	•	•	•	•	•	•

DIFFERENTIAL PRESSURE INDICATORS

Series	Configuration example 1:								Configuration example 2:		Configuration example 3:		Configuration example 4:		Configuration example 5:	
DE Electrical differential pressure indicator	DE	M	12	H	F	50	P01	DE	U	50	V	A	50	P01	UL	
DL Electrical/Visual differential pressure indicator	DL	E	20	V	A	71	P01	DL	E	20	V	A	71	P01		
DT Electronic differential pressure indicator	DT	A	50	H	F	70	P01	DT	A	50	H	F	70	P01		
DV Visual differential pressure indicator	DV	M	70	V			P01	DV	M	70	V			P01		

Type	DE	DL	DT	DV
A Standard type	•	•	•	A With automatic reset
I I-O Link type	-	-	•	M With manual reset
M With wired electrical connection	•	-	-	
U Standard type 210 bar, UL certified	•	-	-	
E For high power supply	-	•	-	

Pressure setting	DEA	DEM	DEU	DLA	DLE	DT	DVA	DVM
20 2.0 bar	•	•	•	•	•	•	•	•

Seals	DEA	DEM	DEU	DLA	DLE	DT	DVA	DVM
H HNBR	•	•	-	•	•	•	•	•
V FPM	•	•	•	•	•	•	•	•

Thermostat	DEA	DEM	DEU	DLA	DLE	DTA	DTI
A Without thermostat	•	•	•	•	•	-	•
F With thermostat	-	•	-	-	•	•	-

Electrical connections	DEA	DEM	DEU	DLA	DLE	DT
10 Connection AMP Superseal series 1.5	-	•	-	-	-	-
20 Connection AMP Timer Junior	-	•	-	-	-	-
30 Connection Deutsch DT-04-2-P	-	•	-	-	-	-
35 Connection Deutsch DT-04-3-P	-	•	-	-	-	-
50 Connection EN 175301-803	•	-	•	-	•	-
51 Connection EN 175301-803, transparent base with lamps 24 Vdc	-	-	-	•	-	-
52 Connection EN 175301-803, transparent base with lamps 110 Vdc	-	-	-	•	-	-
70 Connection IEC 61076-2-101 D (M12)	-	-	-	-	-	•
71 Connection IEC 61076-2-101 D (M12), black base with lamps 24 Vdc	-	-	-	•	-	-

Option
P01 MP Filtri standard
Pxx Customized

Certifications	DEU	OTHERS
Without	-	•
UL UL certification	•	-

PLUGS

Series	Configuration example	
T2 Plug	T2	H

Seals
H HNBR
V FPM



Technical data

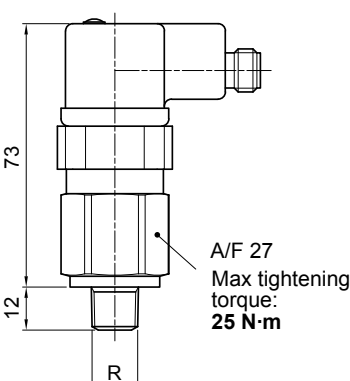
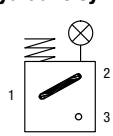
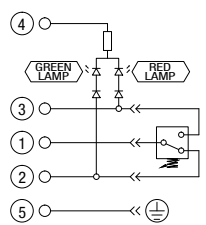

VE*50 (EX)	
Electrical Vacuum Indicator Connection: EN 175301-803	
R	Ordering code
EN 10226 - R1/4"	VE A 21 x A 50 P01 VE A 21 x A 50 P01 EX
EN 10226 - R1/8"	VE B 21 A A 50 P01 VE B 21 A A 50 P01 EX
<p>Hydraulic symbol</p>	
<p>Electrical symbol</p>	
<p>Materials</p> <ul style="list-style-type: none"> - Body: Brass - Base: Black polyamide - Contacts: Silver - Seal: VEA: NBR/FPM VEB: NBR 	
<p>Technical data</p> <ul style="list-style-type: none"> - Vacuum setting: 0.21 bar \pm10% - Max working pressure: 10 bar - Proof pressure: 15 bar - Working temperature: From -25 °C to +80 °C - Compatibility with fluids: Mineral oils, Synthetic fluids HFB and HFC according to ISO 2943 - Degree of protection: IP65 according to EN 60529 	
<p>Electrical data</p> <ul style="list-style-type: none"> - Electrical connection: EN 175301-803 - Resistive load: 5 A / 14 Vdc 4 A / 30 Vdc 5 A / 125 Vac 4 A / 250 Vac 	
<p>Certification: ATEX, IECEx - Certification included in EX version</p>	

VEA50 UL	
Electrical Vacuum Indicator Connection: EN 175301-803	
R	Ordering code
EN 10226 - R1/4"	VE A 21 A A 50 P01 UL
<p>Hydraulic symbol</p>	
<p>Electrical symbol</p>	
<p>Materials</p> <ul style="list-style-type: none"> - Body: Brass - Base: Black polyamide - Contacts: Silver - Seal: VEA: NBR/FPM VEB: NBR 	
<p>Technical data</p> <ul style="list-style-type: none"> - Vacuum setting: 0.21 bar \pm10% - Max working pressure: 10 bar - Proof pressure: 15 bar - Working temperature: From -25 °C to +80 °C - Compatibility with fluids: Mineral oils, Synthetic fluids HFB and HFC according to ISO 2943 - Degree of protection: IP65 according to EN 60529 	
<p>Electrical data</p> <ul style="list-style-type: none"> - Electrical connection: EN 175301-803 - Resistive load: 5 A / 14 Vdc 4 A / 30 Vdc 5 A / 125 Vac 4 A / 250 Vac 	
<p>Certification: UL - Certification included as standard</p>	

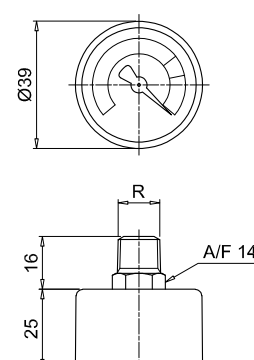
VL*51 - VL*52 - VL*53	
Electrical/Visual Vacuum Indicator Connection: EN 175301-803	
<p>51: Transparent base with lamps 24 Vdc 52: Transparent base with lamps 110 Vdc 53: Transparent base with lamps 230 Vac</p>	
R	Ordering code
EN 10226 - R1/4"	VL A 21 x A xx P01
EN 10226 - R1/8"	VL B 21 A A xx P01
<p>Hydraulic symbol</p>	
<p>Electrical symbol</p>	
<p>Materials</p> <ul style="list-style-type: none"> - Body: Brass - Base: Transparent polyamide - Contacts: Brass - Polyamide - Seal: VLA: NBR/FPM VLB: NBR 	
<p>Technical data</p> <ul style="list-style-type: none"> - Vacuum setting: 0.21 bar \pm10% - Max working pressure: 10 bar - Proof pressure: 15 bar - Working temperature: From -25 °C to +80 °C - Compatibility with fluids: Mineral oils, Synthetic fluids HFB and HFC according to ISO 2943 - Degree of protection: IP65 according to EN 60529 	
<p>Electrical data</p> <ul style="list-style-type: none"> - Electrical connection: EN 175301-803 - Type: 51 52 53 - Lamps: 24 Vdc 110 Vdc 230 Vac - Resistive load: 1 A / 24 Vdc 1 A / 110 Vdc 1 A / 230 Vac 	

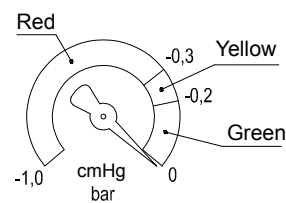
VL*71	
Electrical/Visual Vacuum Indicator Connection IEC 61076-2-101 D (M12), black base with lamps 24 Vdc	
Connections	Indicator code
EN 10226 - R1/4"	VL A 21 x A 71 P01
EN 10226 - R1/8"	VL B 21 A A 71 P01
	
Hydraulic symbol 	
Electrical symbol 	
Materials - Body: Brass - Base: Black polyamide - Contacts: Silver - Seal: VLA: NBR/FPM VL B: NBR	
Technical data - Vacuum setting: 0.21 bar ±10% - Max working pressure: 10 bar - Proof pressure: 15 bar - Working temperature: From -25 °C to +80 °C - Compatibility with fluids: Mineral oils, Synthetic fluids HFB and HFC according to ISO 2943 - Degree of protection: IP65 according to EN 60529	
Electrical data - Electrical connection: IEC 61076-2-101 D (M12) - Lamps: 24 Vdc (black base) - Resistive load: 0.4 A / 24 Vdc	

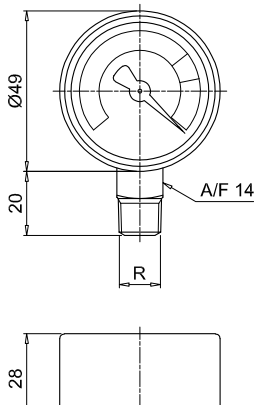
VVA - VVB									
Axial Vacuum Gauge									
R	Ordering code								
EN 10226 - R1/4"	VVA 20 P01								
EN 10226 - R1/8"	VVB 20 P01								
									
Hydraulic symbol 									
Dial scale 									
Conversion to SI units <table border="1" style="margin: auto;"> <thead> <tr> <th>[cmHg]</th> <th>[bar]</th> </tr> </thead> <tbody> <tr> <td>-12</td> <td>-0.16</td> </tr> <tr> <td>-18</td> <td>-0.24</td> </tr> <tr> <td>-76</td> <td>-1.01</td> </tr> </tbody> </table>		[cmHg]	[bar]	-12	-0.16	-18	-0.24	-76	-1.01
[cmHg]	[bar]								
-12	-0.16								
-18	-0.24								
-76	-1.01								
Materials - Case: Black plastic - Window: Clear plastic - Dial: White plastic - Pointer: Black plastic - Pressure connection: Cu-alloy - Pressure element: Bourdon tube Cu-alloy soft soldered, C type - Movement: Cu-alloy									
Technical data - Max working pressure: Steady: -0.7 bar Fluctuating: -0.6 bar Short time: -1.0 bar - Working temperature: Ambienti from -40 °C to +60 °C Fluid max + 60 °C Storage from -40 °C to +60 °C - Compatibility with fluids: Mineral oils, Synthetic fluids HFB and HFC according to ISO 2943 - Accuracy: Class 2.5 according to EN 13190 - Degree of protection: IP31 according to EN 60529									

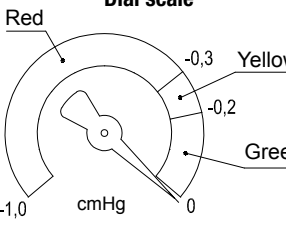
VVR - VVS										
Radial Vacuum Gauge										
R	A/F	Ordering code								
EN 10226 - R1/4"	14	VVR 20 P01								
EN 10226 - R1/8"	11	VVS 20 P01								
										
Hydraulic symbol 										
Dial scale 										
Conversion to SI units <table border="1" style="margin: auto;"> <thead> <tr> <th>[cmHg]</th> <th>[bar]</th> </tr> </thead> <tbody> <tr> <td>-12</td> <td>-0.16</td> </tr> <tr> <td>-18</td> <td>-0.24</td> </tr> <tr> <td>-76</td> <td>-1.01</td> </tr> </tbody> </table>			[cmHg]	[bar]	-12	-0.16	-18	-0.24	-76	-1.01
[cmHg]	[bar]									
-12	-0.16									
-18	-0.24									
-76	-1.01									
Materials - Case: Black plastic - Window: Clear plastic - Dial: White plastic - Pointer: Black plastic - Pressure connection: Cu-alloy - Pressure element: Bourdon tube Cu-alloy soft soldered, C type - Movement: Cu-alloy										
Technical data - Max working pressure: Steady: -0.7 bar Fluctuating: -0.6 bar Short time: -1.0 bar - Working temperature: Ambienti from -40 °C to +60 °C Fluid max + 60 °C Storage from -40 °C to +60 °C - Compatibility with fluids: Mineral oils, Synthetic fluids HFB and HFC according to ISO 2943 - Accuracy: Class 2.5 according to EN 13190 - Degree of protection: IP31 according to EN 60529										

BAROMETRIC (PRESSURE) INDICATORS

Dimensions

BEA*50 (EX)	
Electrical Pressure Indicator Connection EN 175301-803	
Settings	Ordering code
1.5 bar ±10%	BE A 15 H A 50 P01 BE A 15 H A 50 P01 EX
2.0 bar ±10%	BE A 20 H A 50 P01 BE A 20 H A 50 P01 EX

Hydraulic symbol

Electrical symbol

Materials

- Body: Brass
- Base: Black polyamide
- Contacts: Silver
- Seal: HNBR

Technical data

- Max working pressure: 40 bar
- Proof pressure: 60 bar
- Working temperature: From -25 °C to +80 °C
- Compatibility with fluids: Mineral oils, Synthetic fluids
HFB and HFC according to ISO 2943
- Degree of protection: IP65 according to EN 60529

Electrical data

- Electrical connection: EN 175301-803
- Resistive load: 5 A / 14 Vdc
4 A / 30 Vdc
5 A / 125 Vac
4 A / 250 Vac

- Certification: ATEX, IECEx
- Certification included in EX version

BEA*50 UL	
Electrical Pressure Indicator Connection EN 175301-803	
Settings	Ordering code
1.5 bar ±10%	BE A 15 H A 50 P01 UL
2.0 bar ±10%	BE A 20 H A 50 P01 UL

Hydraulic symbol

Electrical symbol

Materials

- Body: Brass
- Base: Black polyamide
- Contacts: Silver
- Seal: HNBR

Technical data

- Max working pressure: 12 bar
- Proof pressure: 40 bar
- Working temperature: From -25 °C to +80 °C
- Compatibility with fluids: Mineral oils, Synthetic fluids
HFB and HFC according to ISO 2943
- Degree of protection: IP65 according to EN 60529

Electrical data

- Electrical connection: EN 175301-803
- Resistive load: 5 A / 14 Vdc
4 A / 30 Vdc
5 A / 125 Vac
4 A / 250 Vac

- Certification: UL
- Certification included as standard

BEM*41	
Electrical Pressure Indicator Connection via four-core cable	
Settings	Ordering code
1.5 bar ±10%	BE M 15 H A 41 P01
2.0 bar ±10%	BE M 20 H A 41 P01

Hydraulic symbol

Electrical symbol

Materials

- Body: Brass
- Base: Black polyamide
- Contacts: Silver
- Seal: HNBR

Technical data

- Max working pressure: 40 bar
- Proof pressure: 60 bar
- Working temperature: From -25 °C to +80 °C
- Compatibility with fluids: Mineral oils, Synthetic fluids
HFB and HFC according to ISO 2943
- Degree of protection: IP67 according to EN 60529

Electrical data

- Electrical connection: Four-core cable
- Resistive load: 5 A / 14 Vdc
4 A / 30 Vdc
5 A / 125 Vac
4 A / 250 Vac

- CE certification
On request this indicator can be provided with main connectors in use for wirings.

BET*F10	
Electrical Pressure Indicator Connection AMP Superseal series 1.5	
Settings	Ordering code
2.0 bar $\pm 10\%$	BET 20 H F 10 P01
2.5 bar $\pm 10\%$	BET 25 H F 10 P01

Hydraulic symbol

Electrical symbol

Materials

- Body: Brass
- Base: Black polyamide
- Contacts: Silver
- Seal: HNBR

Technical data

- Max working pressure: 10 bar
- Proof pressure: 15 bar
- Working temperature: From -25 °C to +100 °C
- Compatibility with fluids: Mineral oils, Synthetic fluids HFB and HFC according to ISO 2943
- Degree of protection: IP65 according to EN 60529

Electrical data

- Electrical connection: AMP Superseal series 1.5
- Resistive load: 0.5 A / 48 Vdc
- Thermostat condition: Open up to 30 °C
- CE certification

BET*F30	
Electrical Pressure Indicator Deutsch DT-04-2-P	
Settings	Ordering code
2.0 bar $\pm 10\%$	BET 20 H F 30 P01
2.5 bar $\pm 10\%$	BET 25 H F 30 P01

Hydraulic symbol

Electrical symbol

Materials

- Body: Brass
- Base: Black polyamide
- Contacts: Silver
- Seal: HNBR

Technical data

- Max working pressure: 10 bar
- Proof pressure: 15 bar
- Working temperature: From -25 °C to +100 °C
- Compatibility with fluids: Mineral oils, Synthetic fluids HFB and HFC according to ISO 2943
- Degree of protection: IP65 according to EN 60529

Electrical data

- Electrical connection: Deutsch DT-04-2-P
- Resistive load: 0.5 A / 48 Vdc
- Thermostat condition: Open up to 30 °C
- CE certification

BET*F50	
Electrical Pressure Indicator Connection EN 175301-803	
Settings	Ordering code
2.0 bar $\pm 10\%$	BET 20 H F 50 P01
2.5 bar $\pm 10\%$	BET 25 H F 50 P01

Hydraulic symbol

Electrical symbol

Materials

- Body: Brass
- Base: Black polyamide
- Contacts: Silver
- Seal: HNBR

Technical data

- Max working pressure: 10 bar
- Proof pressure: 15 bar
- Working temperature: From -25 °C to +100 °C
- Compatibility with fluids: Mineral oils, Synthetic fluids HFB and HFC according to ISO 2943
- Degree of protection: IP65 according to EN 60529

Electrical data

- Electrical connection: EN 175301-803
- Resistive load: 0.5 A / 48 Vdc
- Thermostat condition: Open up to 30 °C
- CE certification

BAROMETRIC (PRESSURE) INDICATORS

Dimensions

BL*51 - BL*52 - BL*53	
Electrical/Visual Pressure Indicator Connection: EN 175301-803	
51: Transparent base with lamps 24 Vdc 52: Transparent base with lamps 110 Vdc 53: Transparent base with lamps 230 Vac	
Settings	Ordering code
1.5 bar \pm 10%	BL A 15 H A xx P01
2.0 bar \pm 10%	BL A 20 H A xx P01
<p>Hydraulic symbol</p>	
<p>Electrical symbol</p>	
<p>Materials</p> <ul style="list-style-type: none"> - Body: Brass - Base: Transparent polyamide - Contacts: Silver - Seal: HNBR 	
<p>Technical data</p> <ul style="list-style-type: none"> - Max working pressure: 40 bar - Proof pressure: 60 bar - Working temperature: From -25 °C to +80 °C - Compatibility with fluids: Mineral oils, Synthetic fluids HFB and HFC according to ISO 2943 - Degree of protection: IP65 according to EN 60529 	
<p>Electrical data</p> <ul style="list-style-type: none"> - Electrical connection: EN 175301-803 - Type: 51 52 53 - Lamps: 24 Vdc 110 Vdc 230 Vac - Resistive load: 1 A / 24 Vdc 1 A / 110 Vdc 1 A / 230 Vac 	

BL*71	
Electrical/Visual Pressure Indicator Connection IEC 61076-2-101 D (M12), black base with lamps 24 Vdc	
Settings	Ordering code
1.5 bar \pm 10%	BL A 15 H A 71 P01
2.0 bar \pm 10%	BL A 20 H A 71 P01
<p>Hydraulic symbol</p>	
<p>Electrical symbol</p>	
<p>Materials</p> <ul style="list-style-type: none"> - Body: Brass - Base: Black polyamide - Contacts: Silver - Seal: HNBR 	
<p>Technical data</p> <ul style="list-style-type: none"> - Max working pressure: 40 bar - Proof pressure: 60 bar - Working temperature: From -25 °C to +80 °C - Compatibility with fluids: Mineral oils, Synthetic fluids HFB and HFC according to ISO 2943 - Degree of protection: IP65 according to EN 60529 	
<p>Electrical data</p> <ul style="list-style-type: none"> - Electrical connection: IEC 61076-2-101 D (M12) - Lamps: 24 Vdc (black base) - Resistive load: 0.4 A / 24 Vdc 	

BVA	
Axial Pressure Gauge	
Settings	Ordering code
1.4 bar \pm 10%	BV A 14 P01
2.5 bar \pm 10%	BV A 25 P01
<p>Hydraulic symbol</p>	
<p>Dial scale</p> <p>BV A 14 P01</p> <p>BV A 25 P01</p>	
<p>Materials</p> <ul style="list-style-type: none"> - Case: Painted Steel - Window: Clear plastic - Dial: Painted Steel - Pointer: Black plastic - Pressure connection: Brass - Pressure element: Bourdon tube Cu-alloy soft soldered, C type - Movement: Cu-alloy 	
<p>Technical data</p> <ul style="list-style-type: none"> - Max working pressure: Static: 7 bar Fluctuating: 6 bar Short time: 10 bar - Working temperature: Ambient from -40 °C to +60 °C Fluid max +60 °C Storage from -40 °C to +60 °C - Compatibility with fluids: Mineral oils, Synthetic fluids HFB and HFC according to ISO 2943 - Accuracy: Class 2.5 according to EN 13190 - Degree of protection: IP31 according to EN 60529 	

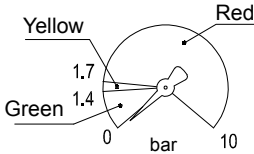
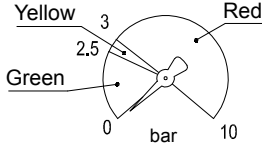
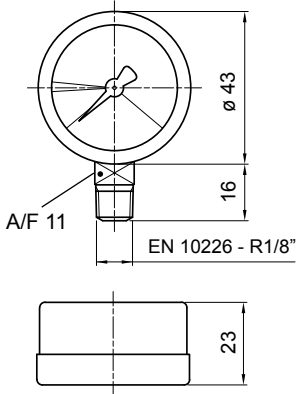
BVR		Hydraulic symbol	Materials
Radial Pressure Gauge			
Settings	Ordering code		
1.4 bar ±10%	BV R 14 P01	Dial scale BV R 14 P01 	
2.5 bar ±10%	BV R 25 P01		BV R 25 P01 
		Technical data - Max working pressure: Static: 7 bar Fluctuating: 6 bar Short time: 10 bar - Working temperature: Ambient from -40 °C to +60 °C Fluid max +60 °C Storage from -40 °C to +60 °C - Compatibility with fluids: Mineral oils, Synthetic fluids HFB and HFC according to ISO 2943 - Accuracy: Class 2.5 according to EN 13190 - Degree of protection: IP31 according to EN 60529	

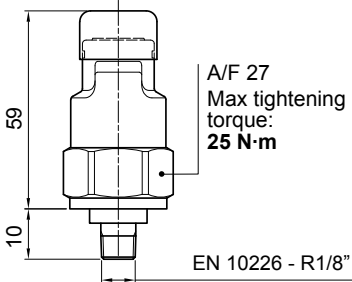
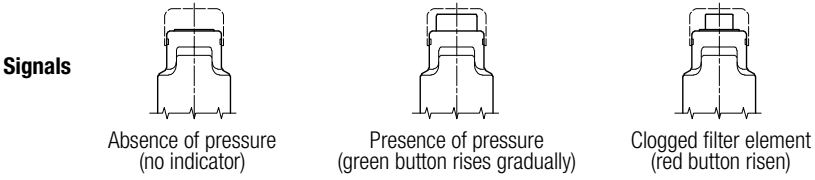
BVP - BVQ		Hydraulic symbol	Materials
Visual Pressure Indicator			
Setting	Ordering code		
1.5 bar ±10%	BV P 15 H P01	Technical data - Reset: BVP - Automatic reset BVQ - Manual reset - Max working pressure: 10 bar - Proof pressure: 15 bar - Working temperature: From -25 °C to +80 °C - Compatibility with fluids: Mineral oils, Synthetic fluids HFB and HFC according to ISO 2943 - Degree of protection: IP45 according to EN 60529	
	BV Q 15 H P01		
2.0 bar ±10%	BV P 20 H P01		
	BV Q 20 H P01		
		Signals Absence of pressure (no indicator) Presence of pressure (green button rises gradually) Clogged filter element (red button risen)	

DIFFERENTIAL PRESSURE INDICATORS

Dimensions

DEA*50	
Electrical Differential Pressure Indicator Connection: EN 175301-803	
Settings	Ordering code
1.2 bar ±10%	DE A 12 x A 50 P01
2.0 bar ±10%	DE A 20 x A 50 P01
5.0 bar ±10%	DE A 50 x A 50 P01
7.0 bar ±10%	DE A 70 x A 50 P01
9.5 bar ±10%	DE A 95 x A 50 P01

A/F 30
Max tightening torque: **65 N·m**

Hydraulic symbol

Electrical symbol

Materials

- Body: Brass
- Base: Black polyamide
- Contacts: Silver
- Seal: HNBR - FPM

Technical data

- Max working pressure: 420 bar
- Proof pressure: 630 bar
- Burst pressure: 1260 bar
- Working temperature: From -25 °C to +110 °C
- Compatibility with fluids: Mineral oils, Synthetic fluids
HFB and HFC according to ISO 2943
- Degree protection: IP66 according to EN 60529
IP69K according to ISO 20653

Electrical data

- Electrical connection: EN 175301-803
- Resistive load: 0.2 A / 115 Vdc

DEH*48	
Hazardous Area Electrical Differential Pressure Indicator Connection via three-core cable - cable fitting M20x1.5	
Settings	Ordering code
2.0 bar ±10%	DE H 20 x A 48 P01
5.0 bar ±10%	DE H 50 x A 48 P01
7.0 bar ±10%	DE H 70 x A 48 P01

A/F 25
Max tightening torque: **100 N·m**

M20 x 1.5

flexible cable ≈ 5000 to A

min. 110

88

Hydraulic symbol

Electrical symbol

Materials

- Body: AISI 316L
- Contacts: Rhodium
- Seal: FPM - MFQ

Technical data

- Max working pressure: 420 bar
- Proof pressure: 630 bar
- Burst pressure: 1260 bar
- Compatibility with fluids: Mineral oils, Synthetic fluids
HFB and HFC according to ISO 2943
- Temperature range: T4=Tamb -60 °C to +125 °C (-76 to 257 °F)
T6=Tamb -60 °C to +80 °C (-76 to 176 °F)
- Degree of protection: IP 66/67/68 according to EN 60529
- Connection type: Three-core cable, fitting M20x1.5
- Contact type: SPCO/SPDT (Hermetically sealed - Volt-free contacts)

Electrical data

- Resistive Load: 830 mA / 24 Vdc - 180 mA / 110 Vac
- Electrical Ratings: Ui = 30 Vdc / li = 250 mA / Pi = 1.3 W

Atex Rating

- II 1 GD Ex ia IIC T6 Ga
- Ex ia IIC T4 Ga
- Ex ia IIIC T₂₀₀ 85 °C Da
- Ex ia IIIC T₂₀₀ 135 °C Da

IECEx Rating

- Ex ia IIC T6 Ga
- Ex ia IIC T4 Ga
- Ex ia IIIC T₂₀₀ 85 °C Da
- Ex ia IIIC T₂₀₀ 135 °C Da

Certification / Approvals: ATEX, IECEx, EAC TR CU
- Certification included as standard

DEH*49	
Hazardous Area Electrical Differential Pressure Indicator Connection via four-core cable - cable fitting 1/2" NPT	
Settings	Ordering code
2.0 bar ±10%	DE H 20 x A 49 P01
5.0 bar ±10%	DE H 50 x A 49 P01
7.0 bar ±10%	DE H 70 x A 49 P01

A/F 25
Max tightening torque: **100 N·m**

1/2" NPT

flexible cable ≈ 5000 to A

min. 110

88

Hydraulic symbol

Electrical symbol

Materials

- Body: AISI 316L
- Contacts: Rhodium
- Seal: FPM - MFQ

Technical data

- Max working pressure: 420 bar
- Proof pressure: 630 bar
- Burst pressure: 1260 bar
- Compatibility with fluids: Mineral oils, Synthetic fluids
HFB and HFC according to ISO 2943
- Temperature range: T4=Tamb -60 °C to +120 °C (-76 to 248 °F)
T6=Tamb -60 °C to +70 °C (-76 to 158 °F)
From -60 °C to +105 °C (-76 to 221 °F) : UL/CSA
- Degree of protection: IP 66/67/68 according to EN 60529
- Connection type: Four-core cable, fitting 1/2" NPT
- Contact type: SPCO/SPDT (Hermetically sealed - Volt-free contacts)

Electrical data

- Resistive Load: 830 mA / 24 Vdc - 180 mA / 110 Vac
- Electrical Ratings: Ui = 150 Vac/dc / Pi = 20 W

Atex Rating

- II 2 GD Ex db IIC T6 Gb
- Ex db IIC T4 Gb
- Ex tb IIIC T85 °C Db
- Ex tb IIIC T135 °C Db

IECEx Rating

- Ex db IIC T6 Gb
- Ex db IIC T4 Gb
- Ex tb IIIC T85 °C Db
- Ex tb IIIC T135 °C Db

UL/CSA Rating

- Class I Div 1 Groups A, B, C, & D
- Class II Div 1 Groups E, F, & G
- Class III Hazardous Locations

Certification / Approvals: ATEX, IECEx, EAC TR CU, UL/CSA
- Certification included as standard

DEH*70	
Hazardous Area Electrical Differential Pressure Indicator Connection IEC 61076-2-101 D (M12)	
Settings	Ordering code
2.0 bar ±10%	DE H 20 x A 70 P01
5.0 bar ±10%	DE H 50 x A 70 P01
7.0 bar ±10%	DE H 70 x A 70 P01

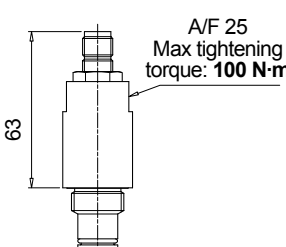

A/F 25
Max tightening torque: **100 N·m**

Hydraulic symbol



Electrical symbol



Materials

- Body: AISI 316L with internal engineered resin switch
- Contacts: Rhodium
- Seal: FPM - MFQ

Technical data

- Max working pressure: 420 bar
- Proof pressure: 630 bar
- Burst pressure: 1260 bar
- Compatibility with fluids: Mineral oils, Synthetic fluids, HFB and HFC according to ISO 2943
- Temperature range: T6=Tamb -60 °C to +80 °C (-76 to 176 °F)
- Degree of protection: IP 66/67 according to EN 60529
- Connection type: IEC 61076-2-101 D (M12)
- Contact type: SPCO/SPDT (Hermetically sealed - Volt-free contacts)

Electrical data

- Resistive Load: 830 mA / 24 Vdc - 180 mA / 110 Vdc
- Electrical Ratings: Ui = 30 Vdc / li = 250 mA / Pi = 1.3 W

Atex Rating
II 1 GD Ex ia IIC T6 Ga
Ex ia IIIC T200 135 °C Da

IECEx Rating
Ex ia IIC T6 Ga
Ex ia IIIC T200 135 °C Da

Certification / Approvals:
ATEX, IECEx, EAC TR CU
- Certification included as standard

DEM*F10	
Electrical Differential Pressure Indicator Connection: AMP Superseal series 1.5	
Settings	Ordering code
1.2 bar ±10%	DE M 12 x F 10 P01
2.0 bar ±10%	DE M 20 x F 10 P01
5.0 bar ±10%	DE M 50 x F 10 P01
7.0 bar ±10%	DE M 70 x F 10 P01
9.5 bar ±10%	DE M 95 x F 10 P01

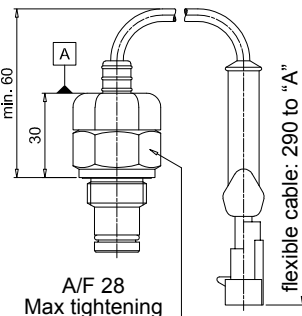

A/F 28
Max tightening torque: **65 N·m**
flexible cable: 290 to "A"

Hydraulic symbol



Electrical symbol

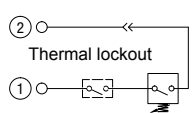

Materials

- Body: Brass
- Base: Black polyamide
- Contacts: Silver
- Seal: HNBR - FPM

Technical data

- Max working pressure: 420 bar
- Proof pressure: 630 bar
- Burst pressure: 1260 bar
- Working temperature: From -25 °C to +110 °C
- Compatibility with fluids: Mineral oils, Synthetic fluids, HFB and HFC according to ISO 2943
- Degree protection: IP66 according to EN 60529

Electrical data

- Electrical connection: AMP Superseal series 1.5
- Resistive load: 0.2 A / 115 Vdc
- Switching type: Normally open contacts (NC on request)
- Thermal lockout: Normally open up to 30 °C (option "F")

DEM*F20	
Electrical Differential Pressure Indicator AMP Time junior	
Settings	Ordering code
1.2 bar ±10%	DE M 12 x F 20 P01
2.0 bar ±10%	DE M 20 x F 20 P01
5.0 bar ±10%	DE M 50 x F 20 P01
7.0 bar ±10%	DE M 70 x F 20 P01
9.5 bar ±10%	DE M 95 x F 20 P01

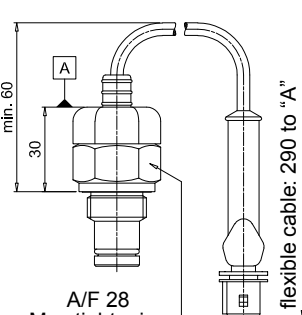

A/F 28
Max tightening torque: **65 N·m**
flexible cable: 290 to "A"

Hydraulic symbol



Electrical symbol

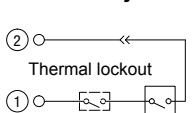

Materials

- Body: Brass
- Base: Black polyamide
- Contacts: Silver
- Seal: HNBR - FPM

Technical data

- Max working pressure: 420 bar
- Proof pressure: 630 bar
- Burst pressure: 1260 bar
- Working temperature: From -25 °C to +110 °C
- Compatibility with fluids: Mineral oils, Synthetic fluids, HFB and HFC according to ISO 2943
- Degree protection: IP66 according to EN 60529

Electrical data

- Electrical connection: AMP Time junior
- Resistive load: 0.2 A / 115 Vdc
- Switching type: Normally open contacts (NC on request)
- Thermal lockout: Normally open up to 30 °C (option "F")

DIFFERENTIAL PRESSURE INDICATORS

Dimensions

DEM*F30	
Electrical Differential Pressure Indicator Deutsch DT-04-2-P	
Settings	Ordering code
1.2 bar ±10%	DE M 12 x F 30 P01
2.0 bar ±10%	DE M 20 x F 30 P01
5.0 bar ±10%	DE M 50 x F 30 P01
7.0 bar ±10%	DE M 70 x F 30 P01
9.5 bar ±10%	DE M 95 x F 30 P01

A/F 28
Max tightening torque: 65 N·m

Hydraulic symbol

Electrical symbol

Materials

- Body: Brass
- Base: Black polyamide
- Contacts: Silver
- Seal: HNBR - FPM

Technical data

- Max working pressure: 420 bar
- Proof pressure: 630 bar
- Burst pressure: 1260 bar
- Working temperature: From -25 °C to +110 °C
- Compatibility with fluids: Mineral oils, Synthetic fluids
HFB and HFC according to ISO 2943
- Degree protection: IP66 according to EN 60529

Electrical data

- Electrical connection: Deutsch DT-04-2-P
- Resistive load: 0.2 A / 115 Vdc
- Switching type: Normally open contacts (NC on request)
- Thermal lockout: Normally open up to 30 °C (option "F")

DEM*F35	
Electrical Differential Pressure Indicator Deutsch DT-04-3-P	
Settings	Ordering code
1.2 bar ±10%	DE M 12 x F 35 P01
2.0 bar ±10%	DE M 20 x F 35 P01
5.0 bar ±10%	DE M 50 x F 35 P01
7.0 bar ±10%	DE M 70 x F 35 P01
9.5 bar ±10%	DE M 95 x F 35 P01

A/F 28
Max tightening torque: 65 N·m

Hydraulic symbol

Electrical symbol

Materials

- Body: Brass
- Base: Black polyamide
- Contacts: Silver
- Seal: HNBR - FPM

Technical data

- Max working pressure: 420 bar
- Proof pressure: 630 bar
- Burst pressure: 1260 bar
- Working temperature: From -25 °C to +110 °C
- Compatibility with fluids: Mineral oils, Synthetic fluids
HFB and HFC according to ISO 2943
- Degree protection: IP66 according to EN 60529

Electrical data

- Electrical connection: Deutsch DT-04-3-P
- Resistive load: 0.2 A / 115 Vdc
- Switching type: SPDT contact
- Thermal lockout: Normally open up to 30 °C (option "F")

DEM*A10	
Electrical Differential Pressure Indicator Connection: AMP Superseal series 1.5	
Settings	Ordering code
1.2 bar ±10%	DE M 12 x A 10 P01
2.0 bar ±10%	DE M 20 x A 10 P01
5.0 bar ±10%	DE M 50 x A 10 P01
7.0 bar ±10%	DE M 70 x A 10 P01
9.5 bar ±10%	DE M 95 x A 10 P01

A/F 28
Max tightening torque: 65 N·m

Hydraulic symbol

Electrical symbol

Materials

- Body: Brass
- Base: Black polyamide
- Contacts: Silver
- Seal: HNBR - FPM

Technical data

- Max working pressure: 420 bar
- Proof pressure: 630 bar
- Burst pressure: 1260 bar
- Working temperature: From -25 °C to +110 °C
- Compatibility with fluids: Mineral oils, Synthetic fluids
HFB and HFC according to ISO 2943
- Degree protection: IP66 according to EN 60529

Electrical data

- Electrical connection: AMP Superseal series 1.5
- Resistive load: 0.2 A / 115 Vdc
- Switching type: Normally open contacts (NC on request)

DEM*A20
Electrical Differential Pressure Indicator
AMP Time junior

Settings	Ordering code
1.2 bar ±10%	DE M 12 x A 20 P01
2.0 bar ±10%	DE M 20 x A 20 P01
5.0 bar ±10%	DE M 50 x A 20 P01
7.0 bar ±10%	DE M 70 x A 20 P01
9.5 bar ±10%	DE M 95 x A 20 P01

A/F 28
Max tightening torque: **65 N·m**

Hydraulic symbol

Electrical symbol

Materials

- Body: Brass
- Base: Black polyamide
- Contacts: Silver
- Seal: HNBR - FPM

Technical data

- Max working pressure: 420 bar
- Proof pressure: 630 bar
- Burst pressure: 1260 bar
- Working temperature: From -25 °C to +110 °C
- Compatibility with fluids: Mineral oils, Synthetic fluids
HFB and HFC according to ISO 2943
- Degree protection: IP66 according to EN 60529

Electrical data

- Electrical connection: AMP Time junior
- Resistive load: 0.2 A / 115 Vdc
- Switching type: Normally open contacts (NC on request)

DEM*A30
Electrical Differential Pressure Indicator
Deutsch DT-04-2-P

Settings	Ordering code
1.2 bar ±10%	DE M 12 x A 30 P01
2.0 bar ±10%	DE M 20 x A 30 P01
5.0 bar ±10%	DE M 50 x A 30 P01
7.0 bar ±10%	DE M 70 x A 30 P01
9.5 bar ±10%	DE M 95 x A 30 P01

A/F 28
Max tightening torque: **65 N·m**

Hydraulic symbol

Electrical symbol

Materials

- Body: Brass
- Base: Black polyamide
- Contacts: Silver
- Seal: HNBR - FPM

Technical data

- Max working pressure: 420 bar
- Proof pressure: 630 bar
- Burst pressure: 1260 bar
- Working temperature: From -25 °C to +110 °C
- Compatibility with fluids: Mineral oils, Synthetic fluids
HFB and HFC according to ISO 2943
- Degree protection: IP66 according to EN 60529

Electrical data

- Electrical connection: Deutsch DT-04-2-P
- Resistive load: 0.2 A / 115 Vdc
- Switching type: Normally open contacts (NC on request)

DEM*A35
Electrical Differential Pressure Indicator
Deutsch DT-04-3-P

Settings	Ordering code
1.2 bar ±10%	DE M 12 x A 35 P01
2.0 bar ±10%	DE M 20 x A 35 P01
5.0 bar ±10%	DE M 50 x A 35 P01
7.0 bar ±10%	DE M 70 x A 35 P01
9.5 bar ±10%	DE M 95 x A 35 P01

A/F 28
Max tightening torque: **65 N·m**

Hydraulic symbol

Electrical symbol

Materials

- Body: Brass
- Base: Black polyamide
- Contacts: Silver
- Seal: HNBR - FPM

Technical data

- Max working pressure: 420 bar
- Proof pressure: 630 bar
- Burst pressure: 1260 bar
- Working temperature: From -25 °C to +110 °C
- Compatibility with fluids: Mineral oils, Synthetic fluids
HFB and HFC according to ISO 2943
- Degree protection: IP66 according to EN 60529

Electrical data

- Electrical connection: Deutsch DT-04-3-P
- Resistive load: 0.2 A / 115 Vdc
- Switching type: SPDT contact

DIFFERENTIAL PRESSURE INDICATORS

Dimensions

DES*10	
Electrical Differential Pressure Indicator AMP Superseal series 1.5	
Settings	Ordering code
1.2 bar ±10%	DE S 12 H A 10 P01
2.5 bar ±10%	DE S 25 H A 10 P01
4.0 bar ±10%	DE S 40 H A 10 P01

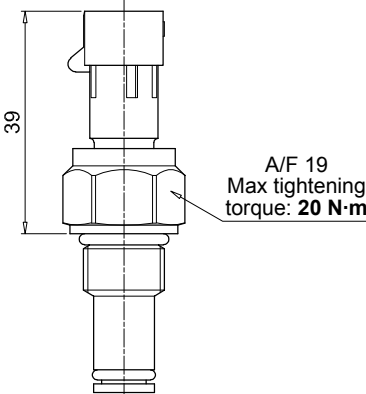

Hydraulic symbol

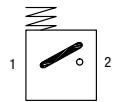

Electrical symbol

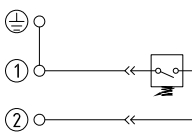

Materials

- Body: Brass
- Internal parts: Brass - Polyamide
- Contacts: Silver
- Seal: HNBR

Technical data

- Max working pressure: 16 bar
- Proof pressure: 24 bar
- Burst pressure: 48 bar
- Working temperature: From -25 °C to +110 °C
- Compatibility with fluids: Mineral oils, Synthetic fluids
HFB and HFC according to ISO 2943
- Degree protection: IP67 according to EN 60529

Electrical data

- Electrical connection: AMP Superseal series 1.5
- Resistive load: 0.2 A / 24 Vdc
- Switching type: Normally open contacts (NC on request)

DES*30	
Electrical Differential Pressure Indicator Deutsch DT-04-2-P	
Settings	Ordering code
1.2 bar ±10%	DE S 12 H A 30 P01
2.5 bar ±10%	DE S 25 H A 30 P01
4.0 bar ±10%	DE S 40 H A 30 P01

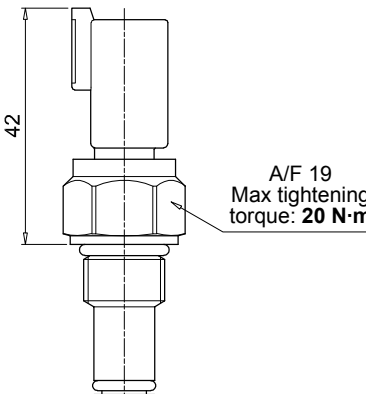

Hydraulic symbol

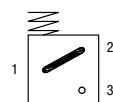

Electrical symbol

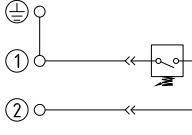

Materials

- Body: Brass
- Internal parts: Brass - Polyamide
- Contacts: Silver
- Seal: HNBR

Technical data

- Max working pressure: 16 bar
- Proof pressure: 24 bar
- Burst pressure: 48 bar
- Working temperature: From -25 °C to +110 °C
- Compatibility with fluids: Mineral oils, Synthetic fluids
HFB and HFC according to ISO 2943
- Degree protection: IP67 according to EN 60529

Electrical data

- Electrical connection: Deutsch DT-04-2-P
- Resistive load: 0.2 A / 24 Vdc
- Switching type: Normally open contacts (NC on request)

DES*50	
Electrical Differential Pressure Indicator Connection: EN 175301-803	
Settings	Ordering code
1.2 bar ±10%	DE S 12 H A 50 P01
2.4 bar ±10%	DE S 25 H A 50 P01
4.0 bar ±10%	DE S 40 H A 50 P01

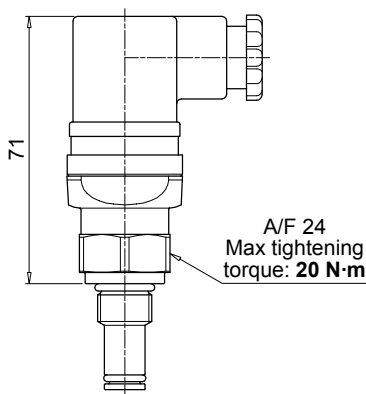

Hydraulic symbol

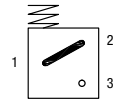

Electrical symbol

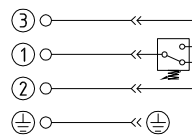

Materials

- Body: Aluminium
- Internal parts: Aluminium - Polyamide
- Contacts: Silver
- Seal: HNBR

Technical data

- Max working pressure: 35 bar
- Proof pressure: 53 bar
- Burst pressure: 105 bar
- Working temperature: From -25 °C to +110 °C
- Compatibility with fluids: Mineral oils, Synthetic fluids
HFB and HFC according to ISO 2943
- Degree protection: IP66 according to EN 60529
IP69K according to EN 20653

Electrical data

- Electrical connection: EN 175301-803
- Resistive load: 0.2 A / 115 Vdc

DES*80	
Electrical Differential Pressure Indicator Stud #10-32 UNF	
Settings	Ordering code
1.2 bar ±10%	DE S 12 HA 80 P01
2.5 bar ±10%	DE S 25 HA 80 P01
4.0 bar ±10%	DE S 40 HA 80 P01

Hydraulic symbol

Electrical symbol

Materials

- Body: Brass
- Internal parts: Brass - Polyamide
- Contacts: Silver
- Seal: HNBR

Technical data

- Max working pressure: 16 bar
- Proof pressure: 24 bar
- Burst pressure: 48 bar
- Working temperature: From -25 °C to +110 °C
- Compatibility with fluids: Mineral oils, Synthetic fluids
HFB and HFC according to ISO 2943
- Degree protection: IP67 according to EN 60529

Electrical data

- Electrical connection: Stud #10-32 UNF
- Resistive load: 0.2 A / 24 Vdc
- Switching type: Normally open contacts (NC on request)

DEU*50 UL	
Electrical Differential Pressure Indicator Connection EN 175301-803	
Settings	Ordering code
2.0 bar ±10%	DE U 20 V A 50 P01 UL
5.0 bar ±10%	DE U 50 V A 50 P01 UL
7.0 bar ±10%	DE U 70 V A 50 P01 UL

Hydraulic symbol

Electrical symbol

Materials

- Body: Brass
- Base: Black Polyamide
- Contacts: Silver
- Seal: FPM

Technical data

- Max working pressure: 210 bar
- Proof pressure: 220 bar
- Burst pressure: 880 bar
- Working temperature: From -25 °C to +85 °C
- Compatibility with fluids: Mineral oils, Synthetic fluids
HFB and HFC according to ISO 2943
- Degree protection: IP65 according to EN 60529

Electrical data

- Electrical connection: EN 175301-803
- Resistive load: 3 A / 30 Vdc
3 A / 125 Vac
3 (3) A / 250 Vac

Certification: UL
- Certification included as standard

DEX*50	
Electrical Differential Pressure Indicator Connection: EN 175301-803	
Settings	Ordering code
1.2 bar ±10%	DE X 12 x A 50 P01
2.0 bar ±10%	DE X 20 x A 50 P01
5.0 bar ±10%	DE X 50 x A 50 P01
7.0 bar ±10%	DE X 70 x A 50 P01
9.5 bar ±10%	DE X 95 x A 50 P01

Hydraulic symbol

Electrical symbol

Materials

- Body: AISI 316L
- Base: Black polyamide
- Contacts: Silver
- Seal: HNBR - MFQ

Technical data

- Max working pressure: 420 bar
- Proof pressure: 630 bar
- Burst pressure: 1260 bar
- Working temperature: From -25 °C to +110 °C
- Compatibility with fluids: Mineral oils, Synthetic fluids
HFB and HFC according to ISO 2943
- Degree protection: IP66 according to EN 60529
IP69K according to ISO 20653

Electrical data

- Electrical connection: EN 175301-803
- Resistive load: 0.2 A / 115 Vdc

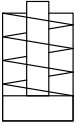
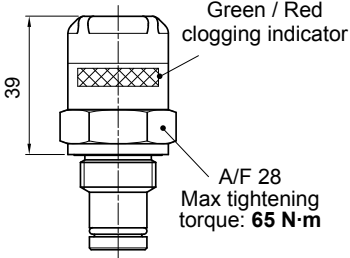
DVA		Hydraulic symbol	Materials
Visual Differential Pressure Indicator			
Settings	Ordering code		- Body: Brass - Internal parts: Brass - Polyamide - Seal: HNBR - FPM
1.2 bar ±10%	DV A 12 x P01		
2.0 bar ±10%	DV A 20 x P01		
5.0 bar ±10%	DV A 50 x P01		
7.0 bar ±10%	DV A 70 x P01		
9.5 bar ±10%	DV A 95 x P01	Technical data - Reset: Automatic reset - Max working pressure: 420 bar - Proof pressure: 630 bar - Burst pressure: 1260 bar - Working temperature: From -25 °C to +110 °C - Compatibility with fluids: Mineral oils, Synthetic fluids HFB and HFC according to ISO 2943 - Degree protection: IP65 according to EN 60529	
			

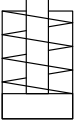
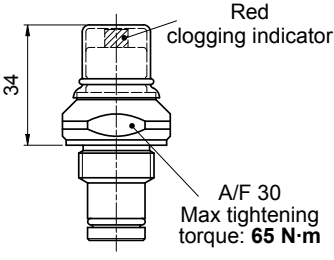
DVM		Hydraulic symbol	Materials
Visual Differential Pressure Indicator			
Settings	Ordering code		- Body: Brass - Internal parts: Brass - Polyamide - Seal: HNBR - FPM
1.2 bar ±10%	DV M 12 x P01		
2.0 bar ±10%	DV M 20 x P01		
5.0 bar ±10%	DV M 50 x P01		
7.0 bar ±10%	DV M 70 x P01		
9.5 bar ±10%	DV M 95 x P01	Technical data - Reset: Manual reset - Max working pressure: 420 bar - Proof pressure: 630 bar - Burst pressure: 1260 bar - Working temperature: From -25 °C to +110 °C - Compatibility with fluids: Mineral oils, Synthetic fluids HFB and HFC according to ISO 2943 - Degree protection: IP65 according to EN 60529	
			

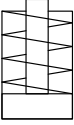
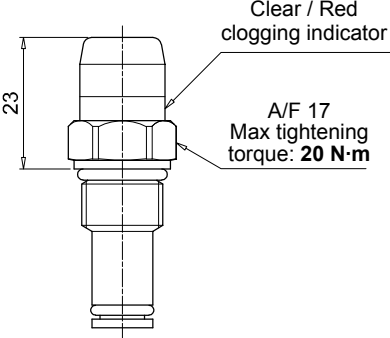
DVS		Hydraulic symbol	Materials
Visual Differential Pressure Indicator Connection: EN 175301-803			
Settings	Ordering code		- Body: Brass - Internal parts: Brass - Polyamide - Seal: HNBR
1.2 bar ±10%	DV S 12 H P01		
2.5 bar ±10%	DV S 25 H P01		
4.0 bar ±10%	DV S 40 H P01		
		Technical data - Reset: Automatic reset - Max working pressure: 35 bar - Proof pressure: 53 bar - Burst pressure: 105 bar - Working temperature: From -25 °C to +110 °C - Compatibility with fluids: Mineral oils, Synthetic fluids HFB and HFC according to ISO 2943 - Degree protection: IP67 according to EN 60529	

DIFFERENTIAL PRESSURE INDICATORS

Dimensions

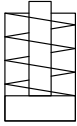
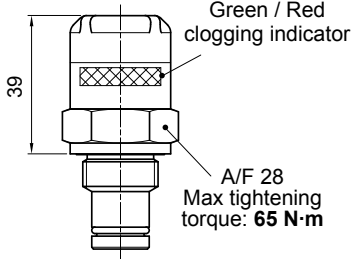
DVX		Hydraulic symbol	Materials
Visual Differential Pressure Indicator			
Settings	Ordering code		- Body: AISI 316L - Internal parts: AISI 316L - Polyamide - Seal: HNBR - MFQ
1.2 bar ±10%	DV X 12 x P01		
2.0 bar ±10%	DV X 20 x P01		
5.0 bar ±10%	DV X 50 x P01		
7.0 bar ±10%	DV X 70 x P01		
9.5 bar ±10%	DV X 95 x P01	Technical data - Reset: Automatic reset - Max working pressure: 420 bar - Proof pressure: 630 bar - Burst pressure: 1260 bar - Working temperature: From -25 °C to +110 °C - Compatibility with fluids: Mineral oils, Synthetic fluids HFB and HFC according to ISO 2943 - Degree protection: IP65 according to EN 60529	
			

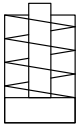
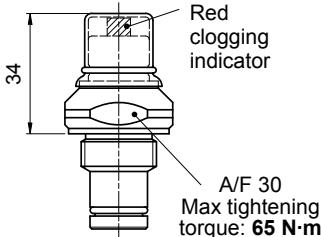
DVY		Hydraulic symbol	Materials
Visual Differential Pressure Indicator			
Settings	Ordering code		- Body: AISI 316L - Internal parts: AISI 316L - Polyamide - Seal: HNBR - MFQ
1.2 bar ±10%	DV Y 12 x P01		
2.0 bar ±10%	DV Y 20 x P01		
5.0 bar ±10%	DV Y 50 x P01		
7.0 bar ±10%	DV Y 70 x P01		
9.5 bar ±10%	DV Y 95 x P01	Technical data - Reset: Manual reset - Max working pressure: 420 bar - Proof pressure: 630 bar - Burst pressure: 1260 bar - Working temperature: From -25 °C to +110 °C - Compatibility with fluids: Mineral oils, Synthetic fluids HFB and HFC according to ISO 2943 - Degree protection: IP65 according to EN 60529	
			

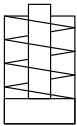
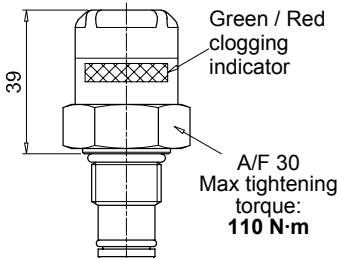
DVZ		Hydraulic symbol	Materials
Visual Differential Pressure Indicator			
Settings	Ordering code		- Body: AISI 316L - Internal parts: AISI 316L - Polyamide - Seal: HNBR - MFQ
1.2 bar ±10%	DV Z 12 x P01		
2.5 bar ±10%	DV Z 25 x P01		
5.0 bar ±10%	DV Z 50 x P01		
7.0 bar ±10%	DV Z 70 x P01		
9.5 bar ±10%	DV Z 95 x P01	Technical data - Reset: Automatic reset - Max working pressure: 700 bar - Proof pressure: 1050 bar - Burst pressure: 2100 bar - Working temperature: From -25 °C to +110 °C - Compatibility with fluids: Mineral oils, Synthetic fluids HFB and HFC according to ISO 2943 - Degree protection: IP65 according to EN 60529	
			

T2	
Plug	
Seal	Ordering code
HNBR	T2 H
FPM	T2 V

Materials

- Body: Phosphatized steel
- Seal: HNBR / FPM

T4	
Plug	
Seal	Ordering code
NBR	T4 A

Materials

- Body: Anodized aluminium
- Seal: NBR

X2	
Stainless Steel plug 420 bar	
Seal	Ordering code
HNBR	X2 H
FPM	X2 V
MFQ	X2 F

Materials

- Body: AISI 316L
- Seal: HNBR / FPM / MFQ

X3	
Stainless Steel plug 700 bar (only for FZH)	
Seal	Ordering code
HNBR	X3 H
FPM	X3 V
MFQ	X3 F

Materials

- Body: AISI 316L
- Seal: HNBR / FPM / MFQ

WORLDWIDE NETWORK

CANADA ♦ CHINA ♦ FRANCE ♦ GERMANY ♦ INDIA ♦ SINGAPORE
UNITED ARAB EMIRATES ♦ UNITED KINGDOM ♦ USA



PASSION  PERFORM

in @ y f



mpfiltri.com
Scan or click me!

MP Filtri reserves the right to make modifications to the models and versions of the described products at any time for both technical and/or commercial reasons. For updated information please visit our website: www.mpfiltri.com. The colors and the pictures of the products are purely indicative. Any reproduction, partial or total, of this document is strictly forbidden. All rights are strictly reserved.

MF001000017
EN - 2026.04