

# FMP series

Maximum working pressure up to 32 MPa (320 bar) - Flow rate up to 500 l/min



## INSTALLATION, SERVICE AND MAINTENANCE MANUAL AND SAFETY INSTRUCTIONS



FMP065



FMP135



FMP320

Please scan or click the QR codes to get updated electronic version of the related document.



*For all the QR codes: Scan or click me!*

## Description

## Technical data

### High Pressure filters

#### In-line

**Maximum working pressure up to 32 MPa (320 bar)**

**Flow rate up to 500 l/min**

FMP is a range of versatile high pressure filter for protection of sensitive components in high pressure hydraulic systems in the industrial equipment.

They are directly connected to the lines of the system through the hydraulic fittings.

#### Available features:

- Female threaded connections up to 1 1/2" and flanged connections up to 1 1/2", for a maximum flow rate of 500 l/min
- Fine filtration rating, to get a good cleanliness level into the system
- Bypass valve, to relieve excessive pressure drop across the filter media
- Check valve, to protect the system against reverse flow
- Low collapse filter element "N", for use with filters provided with bypass valve
- High collapse filter element "H", for use with filters not provided with bypass valve
- Low collapse filter element with external support "R", for filter element protection against the back pressure caused by the check valve in filters provided with the bypass valve
- High collapse filter element with external support "S", for filter element protection against the back pressure caused by the check valve in filters not provided with the bypass valve
- Visual, electrical and electronic differential clogging indicators

#### Common applications:

Delivery lines, in any high pressure industrial equipment or mobile machines

#### Filter housing materials

- Head: Phosphatized cast iron
- Housing: Phosphatized steel
- Bypass valve: Brass
- Reverse Flow: Steel (only for series FMP 320)
- Check valve: Steel

#### Pressure

- Test pressure: 48 MPa (480 bar)
- Min. Burst pressure: 96 MPa (960 bar)
- Pulse pressure fatigue test: 1 000 000 cycles with pressure from 0 to 32 MPa (320 bar)

#### Bypass valve

- Opening pressure 0.6 MPa (6 bar)  $\pm 10\%$
- Other opening pressures on request.

#### Filter element features

Filter FMP		Filter element HP	
$\Delta p$ Element type			
Element media	Construction	$\Delta p$ Series	$\Delta p$
A - Microfiber	Standard	N	20 bar
	With external support	R	20 bar
	High $\Delta p$	H	210 bar
	High $\Delta p$ with external support	S	210 bar
M - Wire mesh	Standard	N	20 bar

*Please see ordering code tables to check element  $\Delta p$  series availability based on filter features.*

**Flow direction through the filter element:**  
From OUT to IN

#### Seals

- Standard NBR series A
- Optional FPM series V

#### Temperature

From -25 °C to +110 °C

#### Note

FMP filters are provided for vertical mounting

#### Connections

In-line Inlet/Outlet

## Weights [kg] and volumes [dm<sup>3</sup>]

Filter series	Weights [kg]					Volumes [dm <sup>3</sup> ]				
	Length	1	2	3	4	Length	1	2	3	4
<b>FMP 065</b>		3.26	3.62	4.83	-		0.36	0.47	0.84	-
<b>FMP 135</b>		5.61	7.21	8.27	-		0.45	0.78	1.00	-
<b>FMP 320</b>		10.95	13.08	15.37	17.85		1.03	1.75	2.52	3.35

Flow rates [l/min]

Filter series	Length	Filter element design - N Series					
		A03	A06	A10	A16	A25	M25
<b>FMP 065</b>	<b>1</b>	23	30	48	54	72	105
	<b>2</b>	31	45	60	65	82	106
	<b>3</b>	52	60	80	84	94	108
<b>FMP 135</b>	<b>1</b>	69	73	120	129	171	201
	<b>2</b>	110	117	149	152	211	232
	<b>3</b>	151	152	192	195	212	233
<b>FMP 320</b>	<b>1</b>	130	144	244	296	361	477
	<b>2</b>	267	291	417	438	492	509
	<b>3</b>	348	390	476	493	503	519
	<b>4</b>	389	415	483	502	525	534

### Maximum flow rate for a complete pressure filter with a pressure drop $\Delta p = 1.5$ bar.

The reference fluid has a kinematic viscosity of 30 mm<sup>2</sup>/s (cSt) and a density of 0.86 kg/dm<sup>3</sup>.

For different pressure drop or fluid viscosity we recommend to use our selection software available on [www.mpfiltri.com](http://www.mpfiltri.com).

You can also calculate the right size using the formulas present on the FILTER SIZING paragraph at the beginning of the full catalogue or at the beginning of the filter family brochure. Please, contact our Sales Department for further additional information.

Hydraulic diagram

Filter series	Style S - E	Style B - C	Style T	Style D
<b>FMP 065</b>	•	•	•	•
<b>FMP 135</b>	•	•	•	•
<b>FMP 320</b>	•	•	•	•

## Pressure drop

### Filter housings $\Delta p$ pressure drop

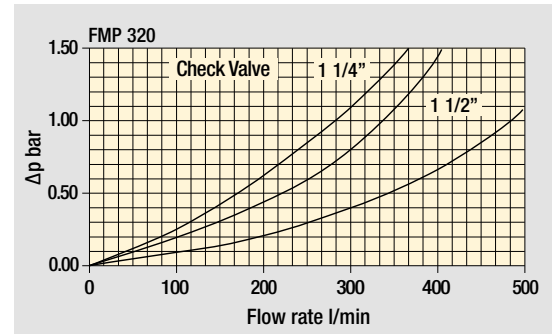
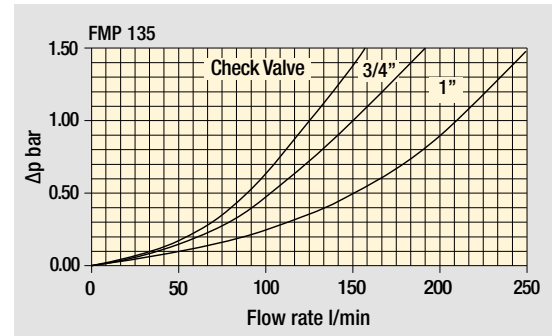
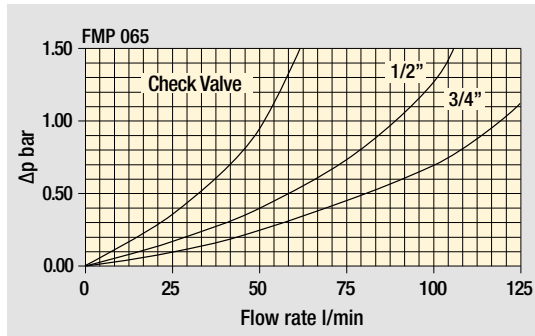

### Bypass valve pressure drop

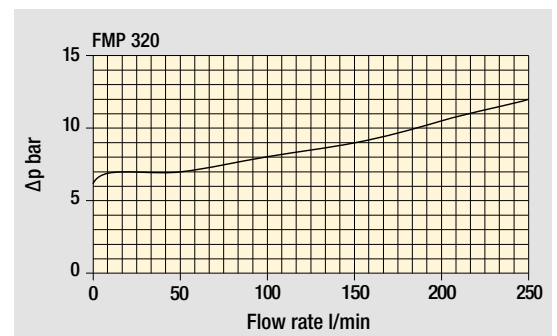
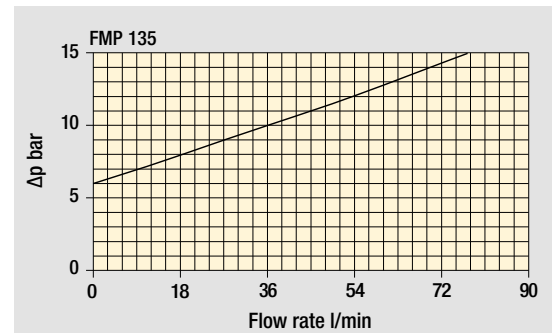
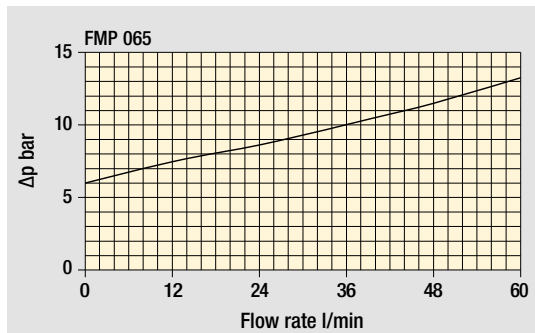

### Valves

#### Filter housing with check valve

- 1 - Reverse flow
- 2 - In filter direction

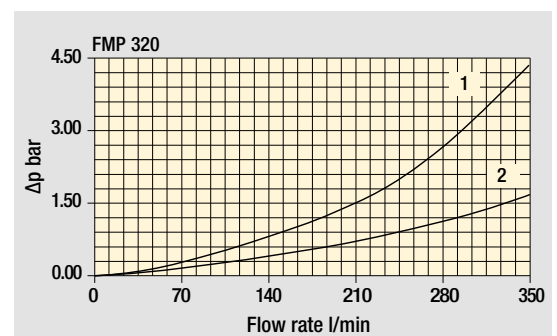

The curves are plotted using mineral oil with density of  $0.86 \text{ kg/dm}^3$  in compliance with ISO 3968.  $\Delta p$  varies proportionally with density.



# FMP FMP065 - FMP135 - FMP320

## Designation & Ordering code

### COMPLETE FILTER

Series and size Configuration example: **FMP065** | **3** | **T** | **A** | **G1** | **M25** | **S** | **P01**

**FMP065** | **FMP135** | **FMP320**

Length	FMP065	FMP135	FMP320
1	•	•	•
2	•	•	•
3	•	•	•
4	-	-	•

Valves	
<b>S</b> Without bypass	<b>C</b> With bypass 6 bar, plug on the opposite side
<b>E</b> Without bypass, plug on the opposite side	<b>T</b> With check valve, without bypass
<b>B</b> With bypass 6 bar	<b>D</b> With check valve, with bypass

Seals	
<b>A</b> NBR	<b>V</b> FPM

Connections	FMP065	FMP135	FMP320
<b>G1</b>	G 1/2"	G 3/4"	G 1 1/4"
<b>G2</b>	G 3/4"	G 1"	G 1 1/2"
<b>G3</b>	1/2" NPT	3/4" NPT	1 1/4" NPT
<b>G4</b>	3/4" NPT	1" NPT	1 1/2" NPT
<b>G5</b>	SAE 8 - 3/4" - 16 UNF	SAE 12 - 1 1/16" - 12 UN	SAE 20 - 1 5/8" - 12 UN
<b>G6</b>	SAE 12 - 1 1/16" - 12 UN	SAE 16 - 1 5/16" - 12 UN	SAE 24 - 1 7/8" - 12 UN
<b>F1</b>	-	3/4" SAE 3000 psi/M	1 1/4" SAE 3000 psi/M
<b>F2</b>	-	1" SAE 3000 psi/M	1 1/2" SAE 3000 psi/M
<b>F3</b>	-	3/4" SAE 3000 psi/UNC	1 1/4" SAE 3000 psi/UNC
<b>F4</b>	-	1" SAE 3000 psi/UNC	1 1/2" SAE 3000 psi/UNC

Filtration rating (filter media)	
<b>A03</b> Inorganic microfiber	3 µm
<b>A06</b> Inorganic microfiber	6 µm
<b>A10</b> Inorganic microfiber	10 µm
<b>A16</b> Inorganic microfiber	16 µm
<b>A25</b> Inorganic microfiber	25 µm
<b>M25</b> Wire mesh	25 µm

Element Δp	Valves					
	S	E	B	C	T	D
<b>N</b> 20 bar	-	-	•	•	-	-
<b>R</b> 20 bar	-	-	-	-	-	•
<b>H</b> 210 bar	•	•	-	-	-	-
<b>S</b> 210 bar	-	-	-	-	•	-

Execution	Filter length			
	1	2	3	4
<b>P01</b> MP Filtri standard	•	•	•	•
<b>P02</b> Maintenance from the bottom of the housing	-	-	-	•
<b>Pxx</b> Customized	-	-	-	-

### FILTER ELEMENT

Element series and size Configuration example: **HP065** | **3** | **M25** | **A** | **S** | **P01**

**HP065** | **HP135** | **HP320**

Element length	HP065	HP135	HP320
1	•	•	•
2	•	•	•
3	•	•	•
4	-	-	•

Filtration rating (filter media)	
<b>A03</b> Inorganic microfiber	3 µm
<b>A06</b> Inorganic microfiber	6 µm
<b>A10</b> Inorganic microfiber	10 µm
<b>A16</b> Inorganic microfiber	16 µm
<b>A25</b> Inorganic microfiber	25 µm
<b>M25</b> Wire mesh	25 µm

Seals	
<b>A</b> NBR	
<b>V</b> FPM	

Element Δp	
<b>N</b> 20 bar	
<b>R</b> 20 bar	
<b>H</b> 210 bar	
<b>S</b> 210 bar	

Execution	
<b>P01</b> MP Filtri standard	
<b>Pxx</b> Customized	

### CLOGGING INDICATORS

See page 786

<b>DEA</b> Electrical differential pressure indicator
<b>DEM</b> Electrical differential pressure indicator
<b>DEU</b> Electrical differential pressure indicator
<b>DLA</b> Electrical / visual differential pressure indicator
<b>DLE</b> Electrical / visual differential pressure indicator

<b>DTA</b> Electronic differential pressure indicator
<b>DTI</b> I-O Link electronic differential pressure indicator
<b>DVA</b> Visual differential pressure indicator
<b>DVM</b> Visual differential pressure indicator

### PLUGS

See page 807

<b>T2</b> Plug (not included)
-------------------------------

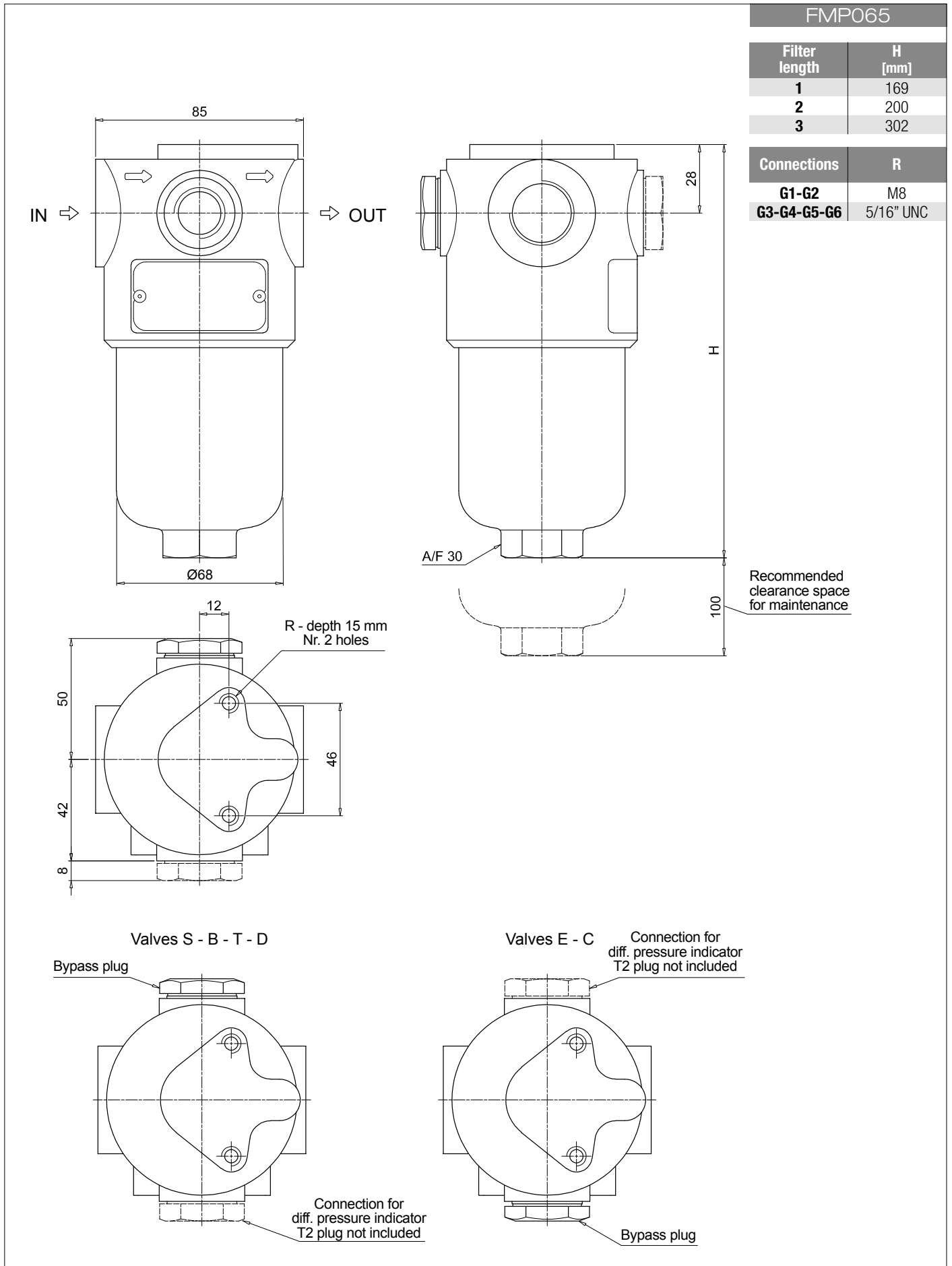

FMP065	
Filter length	H [mm]
1	169
2	200
3	302
Connections	R
G1-G2	M8
G3-G4-G5-G6	5/16" UNC

# FMP FMP065 - FMP135 - FMP320

## Dimensions

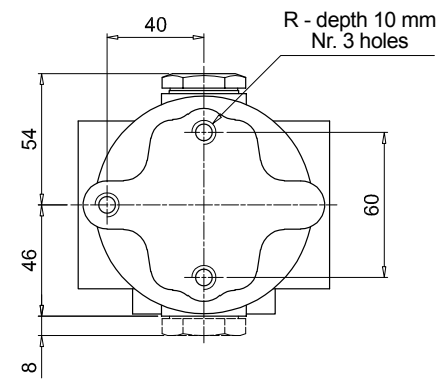
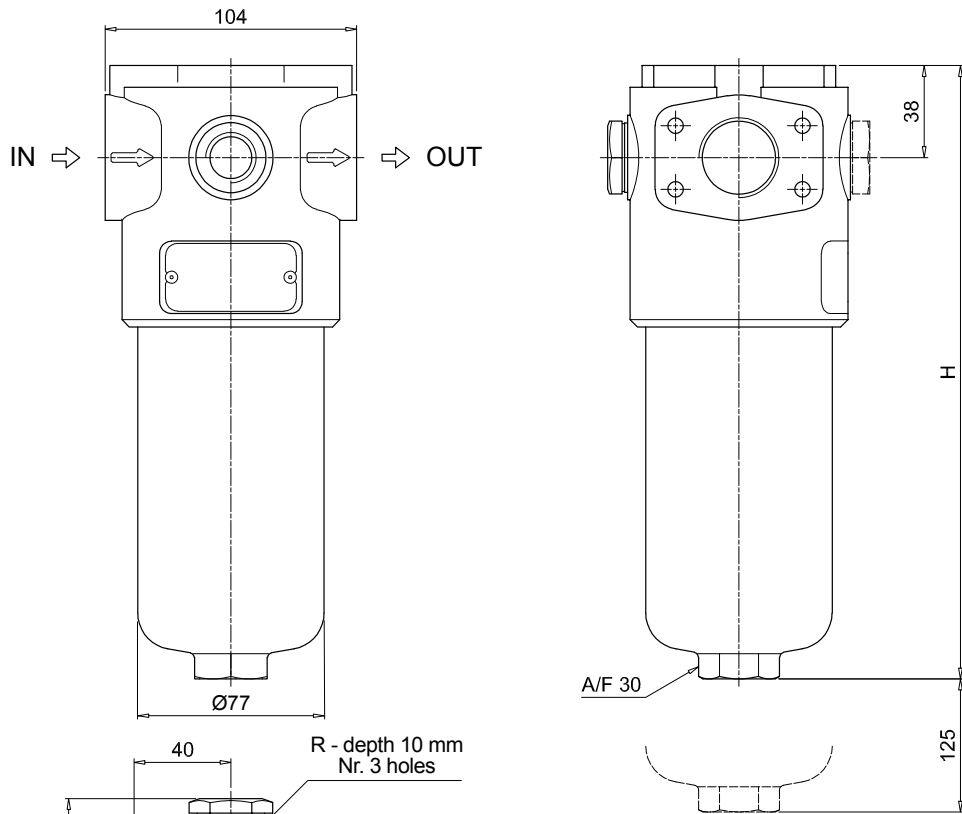

Valves S - B - T - D

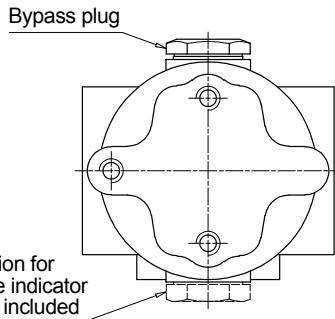

Valves E - C

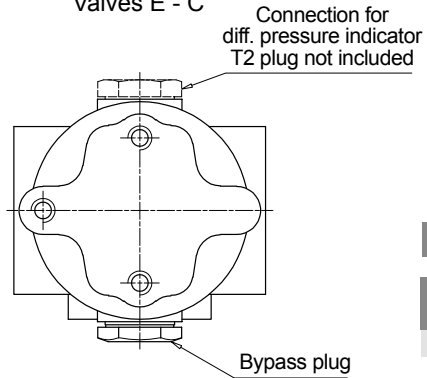

### FMP135

Filter length	H [mm]
1	221
2	334
3	409

Connections	R
G1-G2	M10
G3-G4-G5-G6	3/8" UNC
F1-F2	M10
F3-F4	3/8" UNC

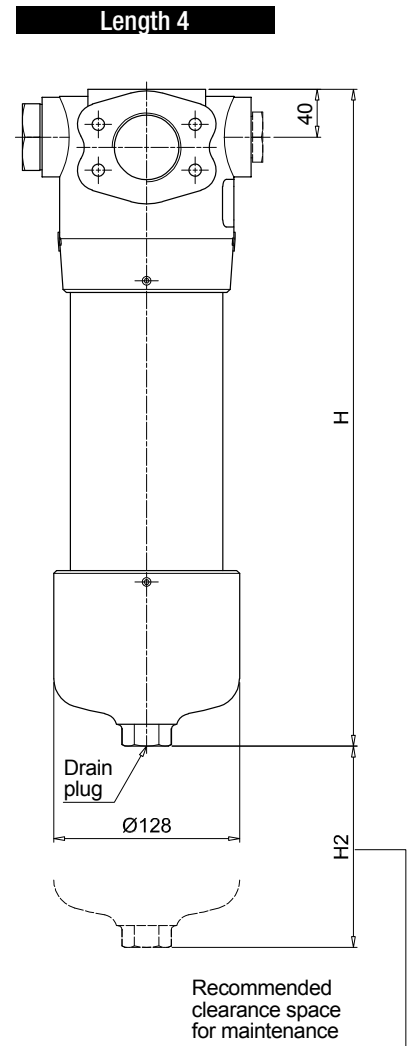
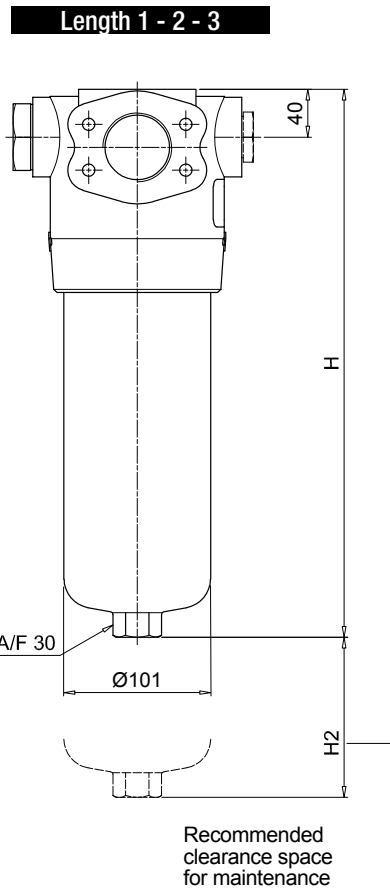
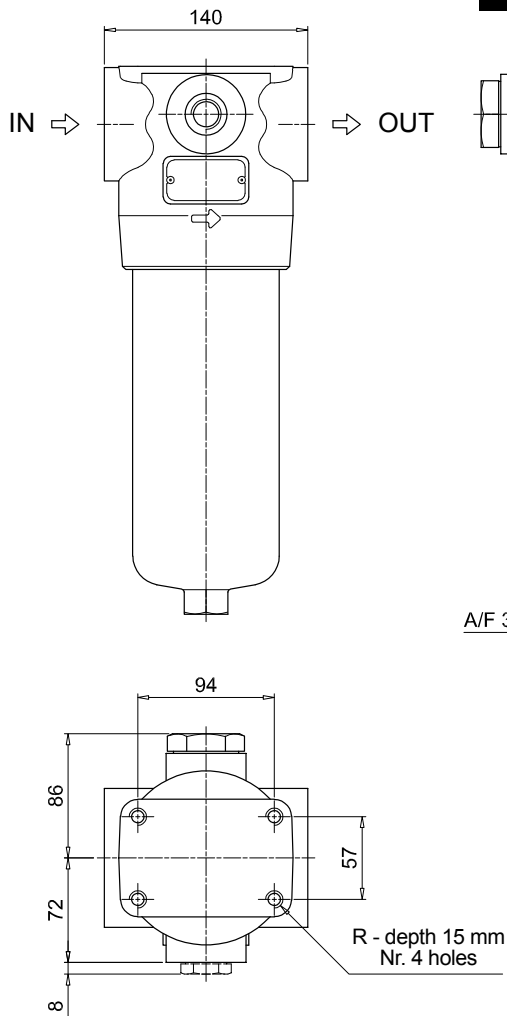

**Valves S - B - T - D**

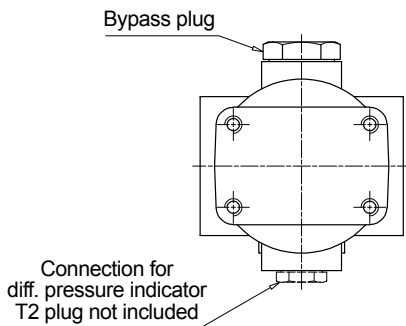

**Valves E - C**

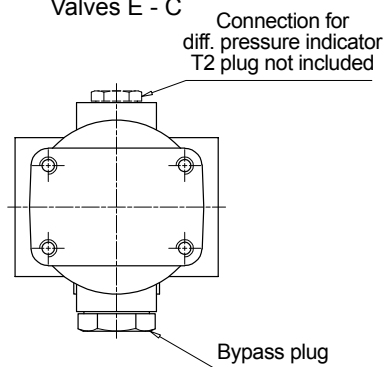

### FMP320

Filter length	H [mm]	H2 [mm]	
		Execution P01	P02
1	263	150	-
2	386	150	-
3	518	150	-
4	671	150	550

Connections	R
<b>G1-G2</b>	M12
<b>G3-G4-G5-G6</b>	1/2" UNC
<b>F1-F2</b>	M12
<b>F3-F4</b>	1/2" UNC

# FMP SPARE PARTS

Order number for spare parts

FMP 065 - 135 - 320

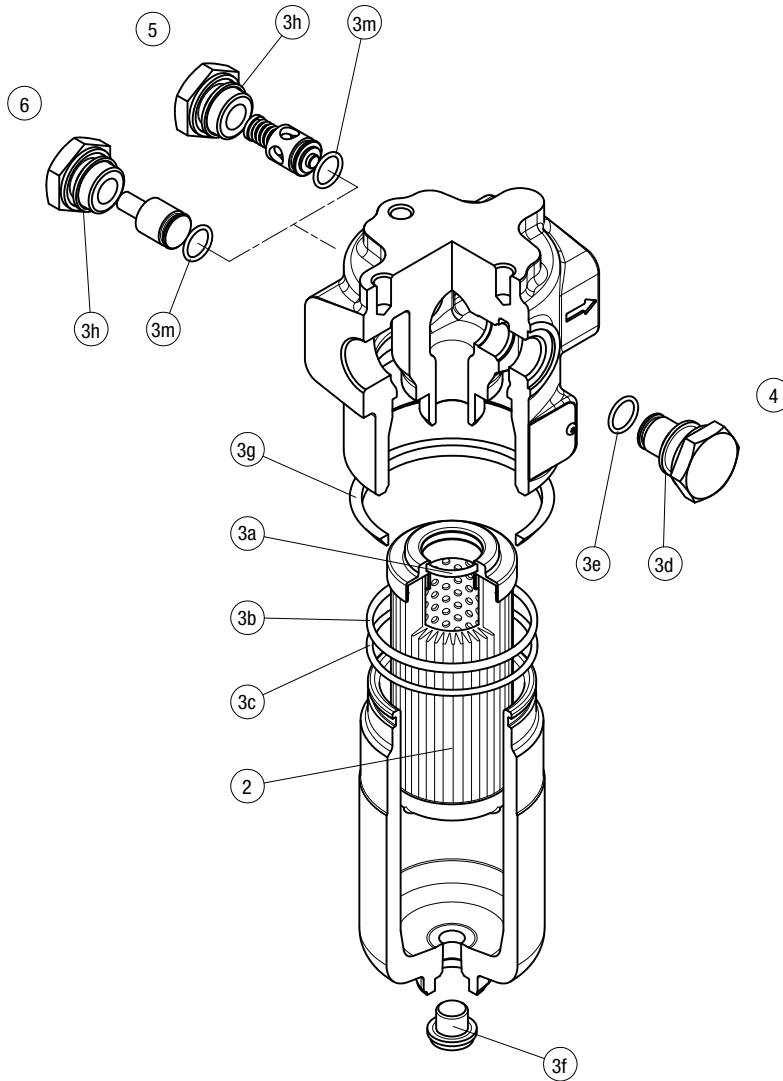

Item:	Q.ty: 1 pc.	Q.ty: 1 pc.		Q.ty: 1 pc.		Q.ty: 1 pc.		Q.ty: 1 pc.	
Filter series	Filter element	Seal Kit code number		Indicator connection plug		Bypass assembly		Non-bypass assembly	
		NBR	FPM	NBR	FPM	NBR	FPM	NBR	FPM
<b>FMP 065</b>	See order table	02050267	02050278			02001312	02001385	02001314	02001386
<b>FMP 135</b>		02050293	02050294	T2H	T2V	02001312	02001385	02001314	02001386
<b>FMP 320</b>		02050274	02050285			02001396	02001397	02001398	02001399